



QUALITY GRIPPING SOLUTIONS...



www.Uni-Techengineers.com



About Us

"As technology advances into all sectors of the industry, tolerances that were once just a dream have become a reality. Clamping technology needs to be maximally precise and reliable in manufacturing and inspection. Hydraulic expanding work and tool holdings are some of the most reliable and high-performance tools used today by leading automobile industries. **Uni-Tech Engineers** established in the year 2012, is armed with a team of young and dynamic professionals, including highly qualified engineers, skilled designers, researchers, and quality controllers. Our company has an excellent reputation as a specialized manufacturer, exporter, and supplier of world-class products, with a commitment to achieving 100% customer satisfaction. We offer Hydraulic Tool Holders, Hydraulic Lock Nuts, Hydraulic Mandrels, Collet Type Expanding Mandrels, Collets, Arbors, Indexable Tool Holders, and also take up all kinds of job works involving Hydraulic Expanding Mandrels, Hydraulic Lock Nuts, and Hydraulic Tool Holders. We have attained great success in the engineering industry."

Quality Assurance

"We have an uncompromising approach towards the quality of our products. We understand that the best quality is the only factor that can efficiently satisfy our customers. To ensure a high standard of quality, we source premium grade raw materials only from reliable vendors and test them at our premises before sending them to the manufacturing unit. The complete manufacturing process is carried out under the vigilant eye of our quality controllers. Finally, each fine-finished piece is rigorously tested by expert quality analysts."

WWW.UNI-TECHENGINEERS.COM



Product Range

"We manufacture and export a wide range of high-quality products that are fabricated from high-grade raw materials. These products are designed and developed using state-of-the-art machinery and equipment, and under the supervision of our team of experts. Our product range includes the following:

- ✓ **Hydraulic expanding Mandrels / Chucks**
 - ✓ **Collet Type Expanding Mandrels / Chucks**
 - ✓ **Inspection Mandrels**
 - ✓ **Turning Mandrels / Chucks**
 - ✓ **Hydraulic Lock Nut**
 - ✓ **CNC Hobbing machine Arbors**
 - ✓ **Threaded Clamping System**
 - ✓ **Collets & Rubber Collets**
 - ✓ **Friction Coating**
- AREA OF APPLICATION**
- ✓ **Gear Hobbing**
 - ✓ **Gear Shaving**
 - ✓ **Gear Grinding**

Repair Works:

"We repair all kinds of Hydraulic Expanding Mandrels and Hydraulic Lock Nuts used in CNC Hobbing Machines, Gear Shaving, and CNC Profile Gear Grinding processes. We also repair Hydraulic Tool Holders used in VMC Machines. Major repairs include issues such as oil refilling, seal replacement, torque testing, and restoration of clamping pressure. However, we do not accept Expanding Mandrels, Hydraulic Nuts, and Hydraulic Tool Holders that are completely damaged or require geometric corrections, or jelly-filled Expanding Mandrels, Hydraulic Nuts, and Hydraulic Tool Holders."



Developed back in the early Fifties for clamping milling cutters on horizontal milling machines.

Simply screw on clamping element in place of mechanical nut. The self-contained hydraulic system is actuated by tightening the pressure screw on the end face by hand, gripping the knurled part of the screw sleeve, or by using a T-hand-led wrench. The parts to be clamped are pressed together by a strong, purely axial force, but remain securely in position due to the absence of any radial or transverse forces.



The hydraulic cushioned clamping surface compensates for any axial run-out, and the axial clamping mechanism is not influenced by the precision of the screw thread and clamping surface.

Milling cutters without keys are clamped by frictional engagement, thus ensuring a perfect driving effect. The clamping force is many times that of the mechanical nut.

Adaptation to the arbor thread and diameter is possible using conversion parts.

UNI-TECH ENGINEERS

Corporate Office :

Plot No. 106/2, T-Block, Shop No. 36,
 Rajgurunagar Industrial Complex,
 Bhosari, Pune, Maharashtra - 411 026

sales@uni-techengineers.com | unitechengineers12@gmail.com

POLYMA

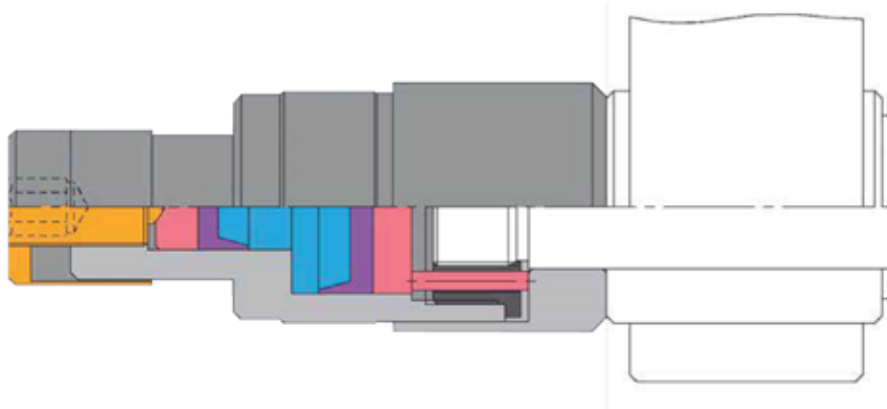

Subject to technical alterations

Technical Data

Please specify arbor O.D. and thread when ordering.

Order No.	Arbor diameter to		Max. clamping force	
	mm	inch	kN	lbs
89-100	32	1.25	120	26400
89-200	50	2.0	150	33000

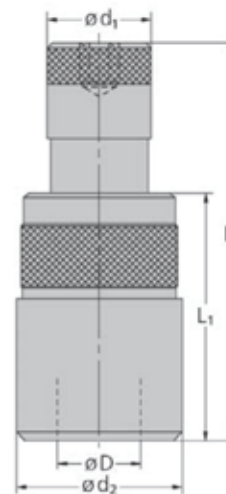

Dimensions

Order No.	Dimensions (mm)				
	ϕD	ϕd_1	ϕd_2	L	L_1
89-100	to 32	41	65	150	97
89-200	to 50	41	83	190	115

Hydraulic power
transmission element 97

VARIO-POLYMA

POLYMA

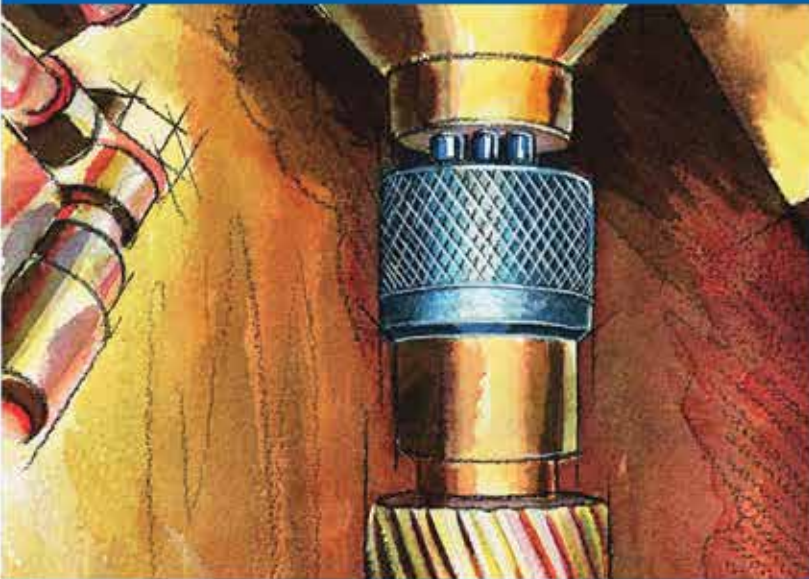

VARIO

Workpieces are clamped by multiplying the pressing force of the machine hydraulics.

Screw on power transmission element by hand. The steady pressure is determined by the machine hydraulics, the force inducted actuates the cylindrical pins. When pressure is applied to these pins, the self-contained hydraulic system of the power transmission element is actuated.



The magnitude of the purely axial clamping force is determined by the transmission ratio and the pressure of the machine hydraulics, and can easily amount to many times the purely mechanical clamping force. No radial forces are generated, so that the parts to be clamped remain aligned in their set positions. The stroke of the clamping piston is limited to approx. 0,5 mm (0.02 inch).

The clamping force is dependent of the screw thread, and the extra tools required by mechanical clamping devices, such as wrench extensions or hammers, can be eliminated.

Depending on the requirements and frame size, the system can also be supplied with a hydraulic resetting mechanism.

UNI-TECH ENGINEERS

Corporate Office :

Plot No. 106/2, T-Block, Shop No. 36,
Rajgurunagar Industrial Complex,
Bhosari, Pune, Maharashtra - 411 026

sales@uni-techengineers.com | unitechengineers12@gmail.com

VARIO-POLYMA

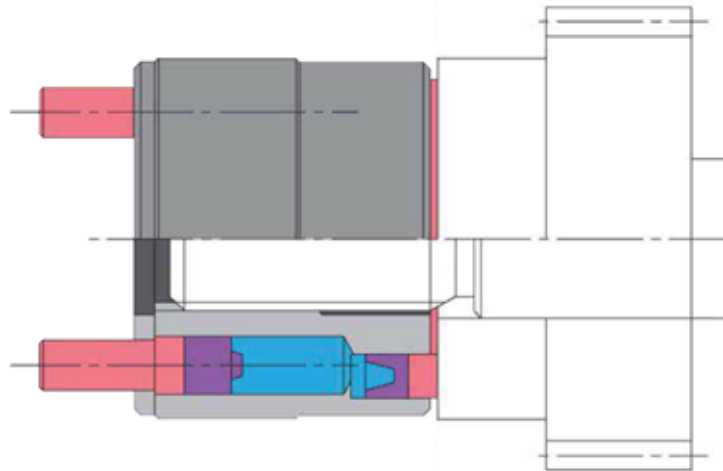

Subject to technical alterations

Technical Data

Please specify thread when ordering.

Order No.	Thread diameter to		Transformation ratio
	mm	inch	
97-100	14	0.500	5:1
97-200	20	0.750	7:1

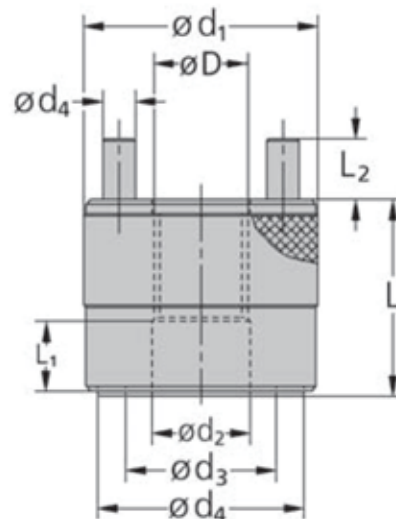

Dimensions

Order No.	Dimensions (mm)								
	Ø D	Ø d ₁	Ø d ₂	Ø d ₃	Ø d ₄	Ø d ₅	L	L ₁	L ₂
97-100	to 14	40	15	22	30	5	34	11	9
97-200	to 20	50	21	32	44	7	41	15	9

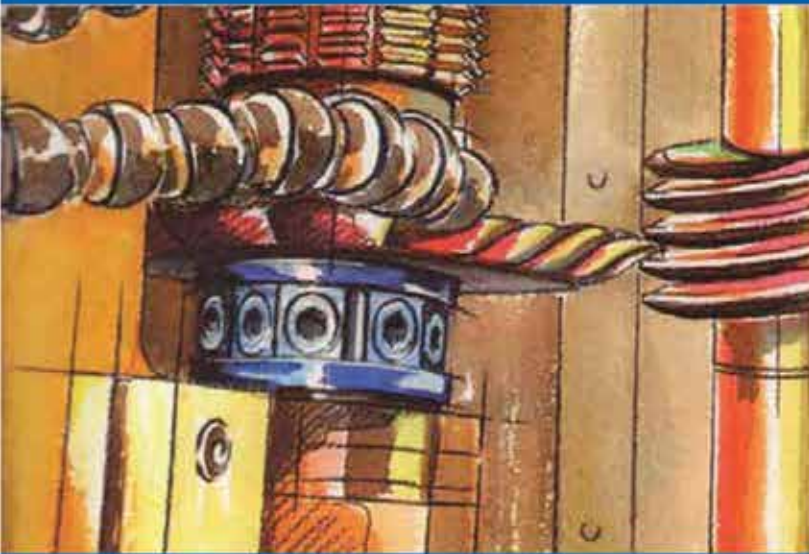

On the basis of our experience with the hydraulic lock nut POLYMA-ADJUSTA No.DAKK92 and the equalizing wedges used there, the development of this purely mechanical alignment ring was obvious.

Operation of the Alignment Ring AK76: Pick up hob, alignment ring, spacer ring etc on the cutting arbor as usual. Obtain the desired purely axial clamping force according to the clamping force indicator by means of the hydraulic lock nut.

- Test the concentricity of the hob.



- Starting with the concentricity minima, correct the reading up to 50% by using the alignment segments.
- Continue to carry out any necessary corrections of the hob concentricity until the required value is achieved.

When choosing the alignment ring, please take into account: The arbor \emptyset and cutter/hob or spacer ring-out side should correspond to measurements D and $d1$. If this is not possible, the following rule of thumb should be applied, when choosing the appropriate alignment : Cutter/Spacer outside diameter= $d1 \pm 5$ mm

Operation of the Alignment Nut AK76-8..:

- Pick up hob, spacer ring, alignment nut etc on the cutting arbor as usual.
- Tighten alignment nut with an openended spanner (SW19).
- Test the concentricity of the hob.
- Starting with the concentricity minima,correct the reading up to 50% by using the alignment segments. Continue to carry out any necessary corrections of the hob concentricity until the required value is achieved.

FACERA

UNI-TECH ENGINEERS

Corporate Office :

Plot No. 106/2, T-Block, Shop No. 36,
Rajgurunagar Industrial Complex,
Bhosari, Pune, Maharashtra - 411 026

sales@uni-techengineers.com | unitechengineers12@gmail.com

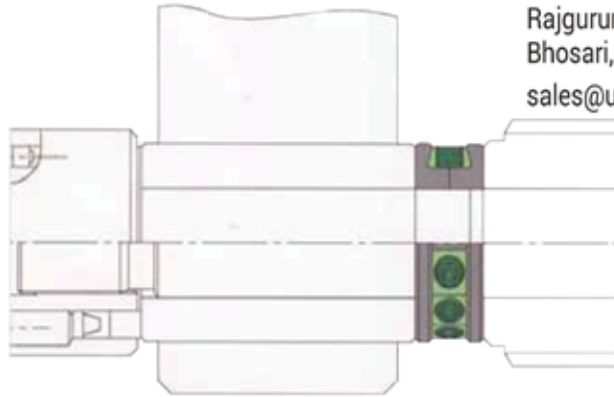

Technical Data

Order specifications for Alignment Ring No. AX76:

Order-No.	Arbor-Ø mm	Outer-Ø mm
AK76-025	.8/10/-	25
AK76-036	-/13/16	36
AK76-042	16/22/27	42
AK76-052	22/27/32	52
AK76-057	22/27/32	57
AK76-065	27/32/40	65
AK76-073	32/40/50	73
AK76-085	40/50/60	85
AK76-105	50/60/80	105
AK76-150	60/80/100	150

Order specifications for Alignment Nut No. AK76-8.

Order-No.	Thread	Outer-Ø mm
AK76-810	M 8 x 0.75	25
AK76-808	M 10 x 0.75	25

Dimensions

Order-No.	Dimensions (mm)		
	ØD	Ø d ₁	L
AK76-025	.8/10/-	25	20
AK76-036	-/13/16	36	20
AK76-042	16/22/27	42	20
AK76-052	16/22/27	52	20
AK76-057	22/27/32	57	20
AK76-065	27/32/40	65	20
AK76-073	32/40/50	73	20
AK76-085	40/50/60	85	20
AK76-105	50/60/80	105	20
AK76-150	60/80/100	150	20
AK76-808	M 8 x 0.75	25	22
AK76-810	M 10 x 0.75	25	22

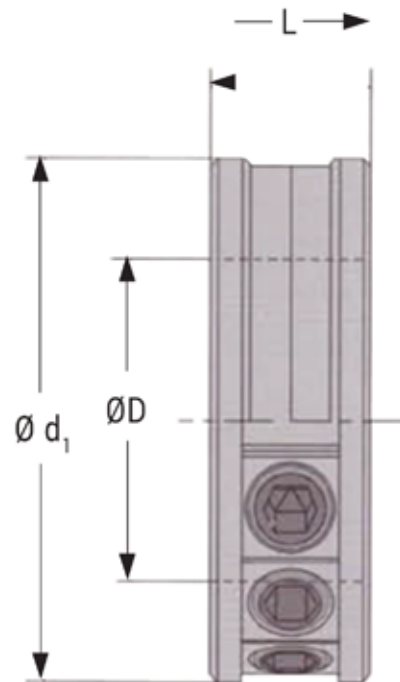

Subject to technical alterations

Hydraulic lock nut D109/DK109

With clamping pressure indicator,
hydraulic retract

POLYMA-THEKA

POLYMA THEKA

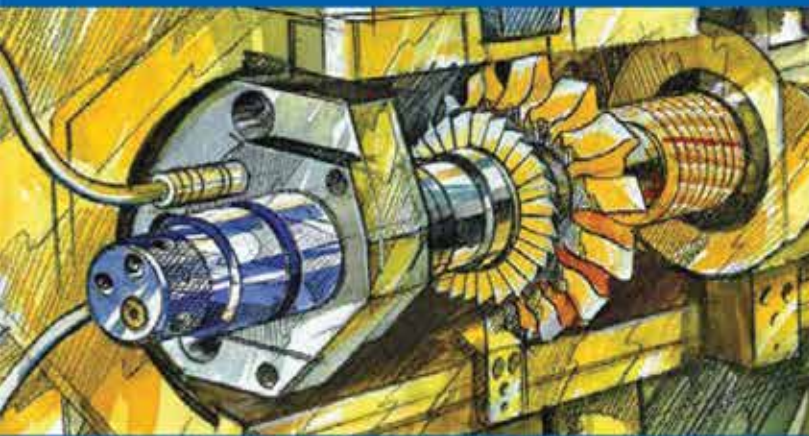

Developed together with GLEASON-PFAUTER for the clamping of the hob cutters it is part of their work standard under number WN41023.

Its outside diameter makes it possible to draw the outer boring over the lock nut so that the cutter arbor with preset hobbing cutters can be changed in spite of the outer bearing being inside.

Tuition of the fully enclosed hydraulic system is effected by tightening the screw on the front. The height of the effective



more axial clamping depends on the cutter arbor and is supervised by the clamping pressure indicator. The clamping pressure is reached as soon as the red ring indicator pin reaches the height of the golden insert. There exist no transverse forces causing a shifting on the hobbing cutter.

The reset of the lock nut with a pressure up to 120 kN (26400 lbs) is manually effected with the internal screw thread.

For machines having a big outer bearing (arbor thread M42x1,5LH) the lock nut DK109-A300 is equipped with hydraulic resets. This makes hydraulics automatically return to zero/initial position.

For the power of supply an Allen wrench is needed. Big wrenches or wrench extensions are no longer used.

Hydraulic lock nut D109/DK109

With clamping pressure indicator, hydraulic retract

UNI-TECH ENGINEERS

Corporate Office :

Plot No. 106/2, T-Block, Shop No. 36,
Rajgurunagar Industrial Complex,
Bhosari, Pune, Maharashtra - 411 026

sales@uni-techengineers.com | unitechengineers12@gmail.com

POLYMA-THEKA

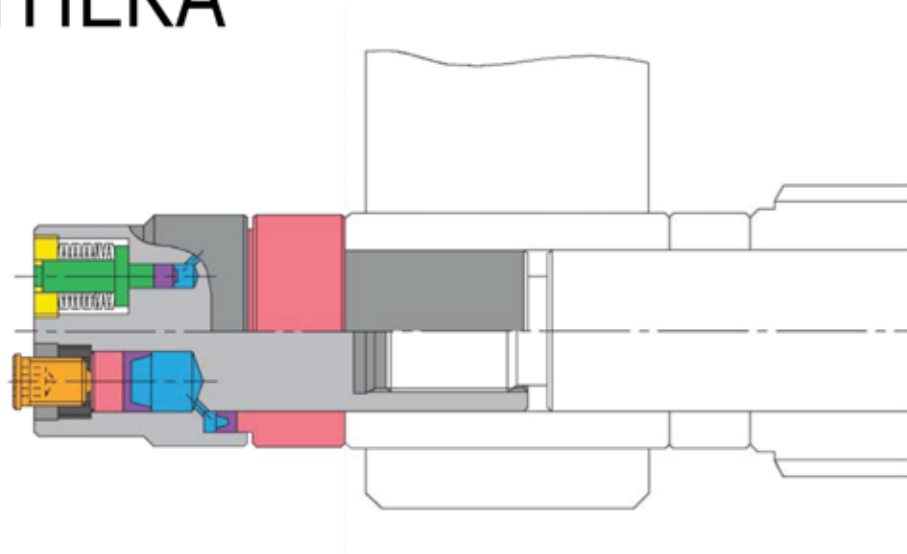

Technical Data

Please specify thread when ordering.

Order No.	Arbor diameter to		Max. clamping force kN	Marked ring	Pressure indicator	
	mm	inch			Clamping force kN	Clamping force lbs
D109-A020	12	0.500	20	1	20	4400
D109-A060	16	0.625	60	1	60	13200
D109-A080	20	0.750	80	1	80	17600
D109-A100	24	0.875	100	1	100	22000
D109-A120	30	1.125	120	1	120	26400
DK109-A300	42	1.625	300	1	300	66000

Dimensions

Order No.	Dimensions (mm)								
	Ø D	Ø d ₁	Ø d ₂	Ø d ₃	L	L ₁	L ₂	L ₃	L ₄ *
D109-A020	to 12	57,5	52	40	117	77	27	38	5
D109-A060	to 16	57,5	52	40	117	77	27	38	5
D109-A080	to 20	57,5	52	40	117	77	27	38	5
D109-A100	to 24	57,5	52	40	117	77	27	38	5
D109-A120	to 30	57,5	52	40	117	77	27	38	5
DK109-A300	to 42	81,5	76	60	150	94	36	54	0

*L₄ = untied screw

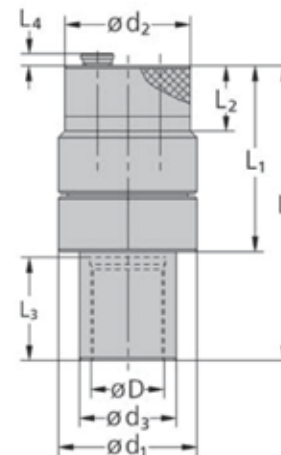

Subject to technical alterations

Hydraulic clamping device D82

With clamping pressure indicator

POLYMA-COCLEA

POLYMA
COCLEA

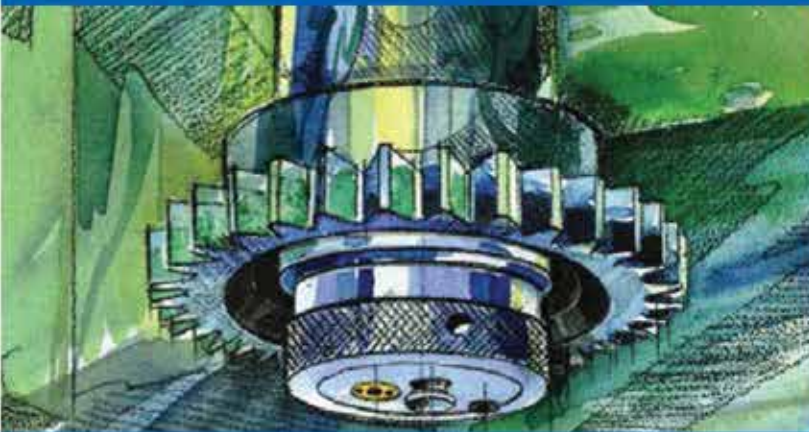

In the form of a screw.

Tighten screw by hand. The self-contained hydraulic system is actuated by tightening the pressure screw on the end face with an Allen wrench. The parts are clamped with a strong, purely axial force. The effective force is defined and monitored by the clamping pressure indicator on the end face. The hydraulically cushioned clamping surface adapts to the part to be clamped.

The pre-set concentricity is maintained, as no radial or transverse forces are generated.



The pressure screw is actuated with an Allen wrench (size 6 mm); other aids, such as wrenches and hammers are not required.



POLYMA-COCLEA

UNI-TECH ENGINEERS

Corporate Office :

Plot No. 106/2, T-Block, Shop No. 36,
Rajgurunagar Industrial Complex,
Bhosari, Pune, Maharashtra - 411 026

sales@uni-techengineers.com | unitechengineers12@gmail.com

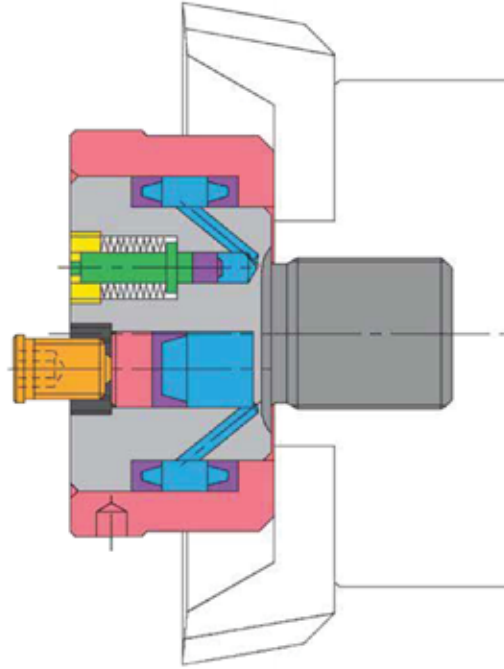

Subject to technical alterations

Technical Data

Please specify diameter d_2 and for D82-200 further desired thread when ordering.

Order No.	Thread diameter		Max. clamping force kN	Marked ring	Pressure indicator Clamping force	
	mm	inch			kN	lbs
D82-A0...	M22x1,5	M22x1,5	40	1	40	8800
D82-A1...	M36x1,5	M36x1,5	60	1	60	13200
D82-200	to 40	1,5	80	1	80	17600

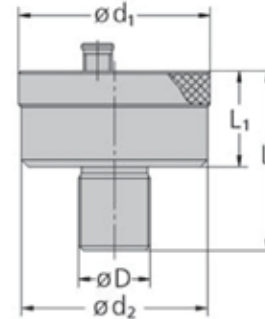

Dimensions

Order No.	Dimensions (mm)				
	$\varnothing D$	$\varnothing d_1$	$\varnothing d_2$	L	L_1
D82-A0...	M22x1,5	46	to 125	56	26
D82-A1...	M36x1,5	60	to 200	56	26
D82-200	to 40	80	to 125	75	42

Hydraulic cutting tool adaptor

D83/DA83/DAZ83/DZ83

With clamping pressure indicator
Purely axial clamping

POLYMA-ADAPTA

POLYMA ADAPTA

Main application so far: clamping of shaper cutters on a gear shaper.

The advantages of hydraulic shaper cutter adaptor clamping over the purely mechanical solution are as follows:

- Significantly higher, purely axial clamping force
- Monitored, defined clamping force by clamping pressure indicator
- no radial or transverse forces to displace the cutter position
- force induction by Allen wrench
- nut or screw for tightening shaper cutter only needs to be hand-tightened
- no need for extended wrenches in mostly cramped conditions
- no risk of injury through slippage of the wrench of spanner wrench
- easier operation and reduced setup times

Depending on the required degree of precision, the following versions are available:

D83: Hydraulically reinforced, purely axial shaper cutter clamp, checked and monitored by clamping pressure indicator.

DA83: As for 083, but with additional facility for aligning concentricity by radially integrated adjusting screws.



D283: As for 083, but with additional hydraulic expanding arbor for close-fitting, optimal bore-hole mounting.

DAZ83: Combination of the above three alternatives, i.e. hydraulically reinforced axial clamp, alignment of holding fixture by adjusting screws and optimal bore centering by hydraulic expanding arbor.

Due to the lack of universal standards, it is only possible to describe basic design options on reverse.

Data needed for designing a hydraulic cutter tool adaptor are: A drawing of the previously used mechanical cutting tool clamp or a drawing of the machine spindle at which the following general versions are possible:

- straight shank with fastening screws
- steep taper or HSK in standard or manufacturer-specific design depending on work pieces and machine work holding fixture.

Modular solutions are possible to suit the amount of space available. In this way, parts of assemblies can be substituted or exchanged according to the degree of wear or the cutting wheel used.



UNI-TECH ENGINEERS

Corporate Office :

Plot No. 106/2, T-Block, Shop No. 36,
Rajgurunagar Industrial Complex,
Bhosari, Pune, Maharashtra - 411 026

sales@uni-techengineers.com | unitechengineers12@gmail.com

DA83:

Tool clamp with hydraulically reinforced, purely axial clamping force and clamping pressure indicator plus concentricity aligning facility for mounting the cutter in the machine. This allows correction of an axial run-out due to the clamp and machine spindle.

POLYMA-ADAPTA

D83:

Tool clamp with hydraulically reinforced, purely axial clamping force and clamping pressure indicator.

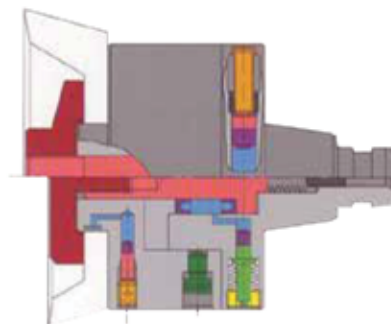
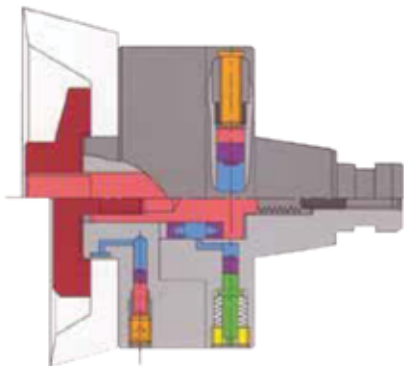
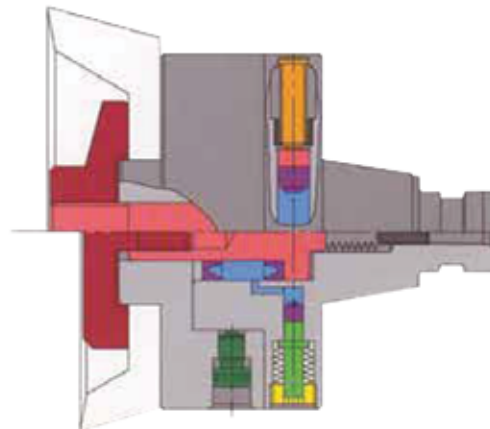
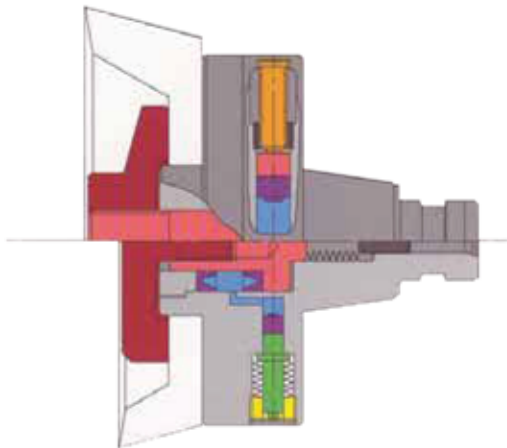

DZ83:

Tool clamp with hydraulically reinforced, purely axial clamping force and clamping pressure indicator plus hydraulic expanding arbor for optimal mounting of tool in bore-hole.

DAZ83:

Tool clamping with hydraulically reinforced, purely axial clamping force and clamping pressure indicator plus facility for aligning the clamp and centering the cutting wheel optimally via a hydraulic expanding arbor.

Hydraulic clamping device D87

With clamping pressure indicator

POLYMA-MAGNA

POLYMA MAGNA

Main application so far: clamping of shaper cutters on a gear shaper.

The advantages of hydraulic shaper cutter adaptor clamping over the purely mechanical solution are as follows:

- Significantly higher, purely axial clamping force
- Monitored, defined clamping force by clamping pressure indicator
- No radial or transverse forces to displace the cutter position
- Force induction by Allen wrench
- Nut or screw for tightening shaper cutter only needs to be hand-tightened

Mainly for clamping workpieces together with clamp and mechanical nut.

The self-contained nature of the hydraulic unit makes it very versatile. The hydraulic clamping element is placed on the clamping screw before the mechanical nut. Tighten the mechanical nut by hand. Actuate the self-contained hydraulic system by tightening the radial screw (max. size 17 mm).

The magnitude of the purely axial force can be adjusted and monitored by the multi-stage clamping pressure indicator.



The clamping pressure indicator is positioned at an angle of 75° to the pressure induction point. If necessary, the calibration of the clamping force can be altered at the factory.

Due to the closed hydraulic system, the stroke of the annular piston is limited to approx. 4 mm (0.157 inch), but a larger stroke is also available on request.

The use of these hydraulic clamping elements represents a genuine contribution to accident prevention and labour saving, as the clamping pressure amounts to many times the force obtainable by purely mechanical means. The extra tools associated with mechanical workpiece clamp, such as wrench extensions and hammers, can be eliminated.

The device is a "must" when clamping larger workpieces.



Hydraulic clamping device D87

With clamping pressure indicator

POLYMA-MAGNA

UNI-TECH ENGINEERS

Corporate Office :

Plot No. 106/2, T-Block, Shop No. 36,
Rajgurunagar Industrial Complex,
Bhosari, Pune, Maharashtra - 411 026

sales@uni-techengineers.com | unitechengineers12@gmail.com

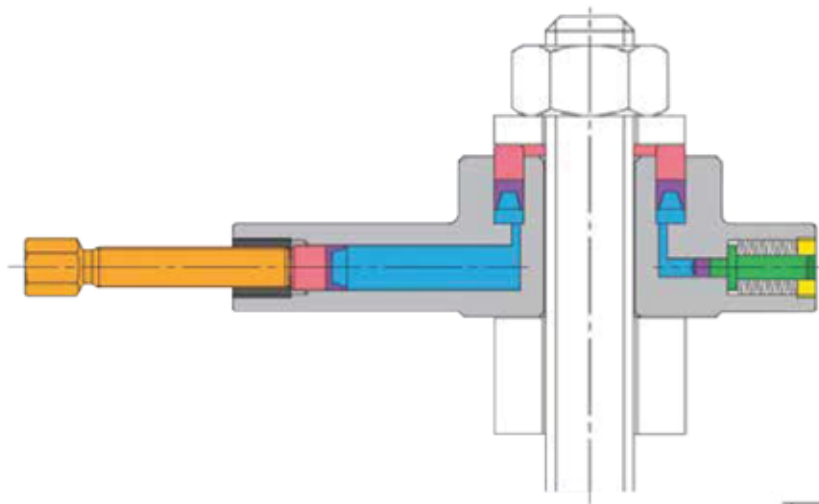

Technical Data

Order No.	Diameter		Max. clamping force kN	Marked ring	Pressure indicator Clamping force	
	mm	inch			kN	lbs
D87-010	23	0.875	100	1	60	13200
				2	100	22000
D87-110	31	1.125	180	1	60	13200
				2	100	22000
				3	180	39600
D87-210	43	1.625	250	1	60	13200
				2	150	33000
				3	250	55000

Dimensions

Order No.	Dimensions (mm)							
	Ø D	Ø d ₁	Ø d ₂	Ø d ₃	Ø d ₄	H	L ₁	L ₂
D87-010	23	60	50	30	28	49	150	120
D87-110	31	90	65	45	30	59	178	138
D87-210	43	110	85	65	35	64	220	172

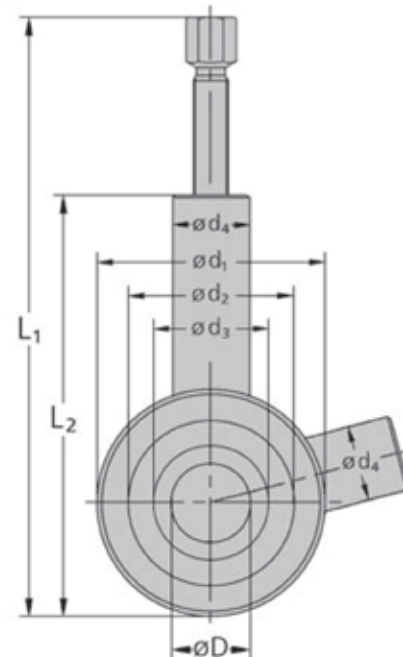

Subject to technical alterations

Hydraulic clamping device D88

With clamping pressure indicator

POLYMA-NOVA

POLYMA NOVA



Mainly used as a spacer ring.

The mechanical nut is still necessary, but only has to be tightened by hand. The purely axial clamping force is generated by tightening the peripheral screws, thus actuating the self-contained hydraulic system. The clamping force thus generated amounts to many times the force obtainable by purely mechanical means. The magnitude of the clamping pressure is adjusted and monitored by means of the built-in-multi-stage clamping pressure indicator.



On request, the graduation and maximum force can be reduced.

Any axial run-out is compensated for by the hydraulically cushioned clamping surface, the parts remain securely in position due to the absence of any radial or transverse forces. Conventional aids, such as wrench extensions or hammers, can be eliminated.

Smaller arbor diameters can be accommodated using your own spacers, thus making the device even more versatile.



Hydraulic clamping device D88

With clamping pressure indicator

POLYMA-NOVA

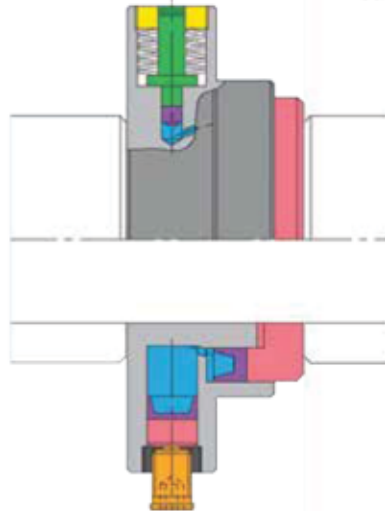

UNI-TECH ENGINEERS

Corporate Office :

Plot No. 106/2, T-Block, Shop No. 36,
Rajgurunagar Industrial Complex,
Bhosari, Pune, Maharashtra - 411 026

sales@uni-techengineers.com | unitechengineers12@gmail.com

Technical Data

Please specify arbor O.D. or thread when ordering.

Order No.	Arbor diameter to		Max. clamping force kN	Marked ring	Pressure indicator Clamping force	
	mm	inch			kN	lbs
D88-100	32	1.25	120	1	60	13200
				2	120	26400
D88-200	50	2.0	160	1	60	13200
				2	100	22000
				3	160	35200
D88-300	80	3.125	160	1	60	13200
				2	100	22000
				3	160	35200
D88-400	110	4.25	200	1	60	13200
				2	120	26400
				3	200	44000
D88-500	120	4.75	200	1	60	13200
				2	120	26400
				3	200	44000

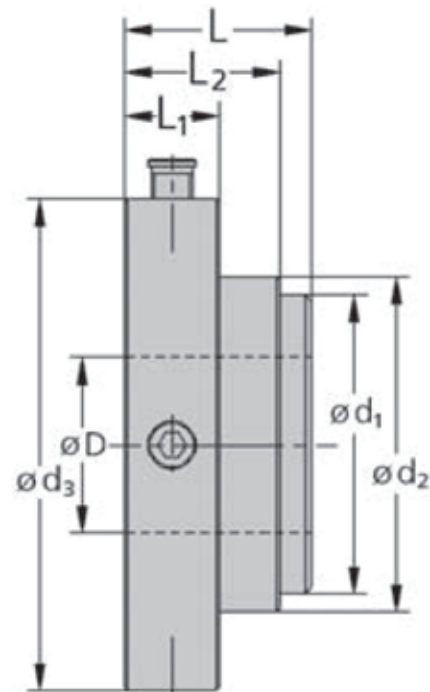

Subject to technical alterations

Dimensions

Order No.	Dimensions (mm)						
	Ø D	Ø d ₁	Ø d ₂	Ø d ₃	L	L ₁	L ₂
D88-100	to 32	65	75	122	52	27	44
D88-200	to 50	85	95	140	52	27	44
D88-300	to 80	115	125	170	52	27	44
D88-400	to 110	132	150	200	52	27	44
D88-500	to 120	160	170	212	52	27	46

Hydraulic lock nut D89

With clamping pressure indicator

POLYMA-PRIMA

POLYMA
PRIMA

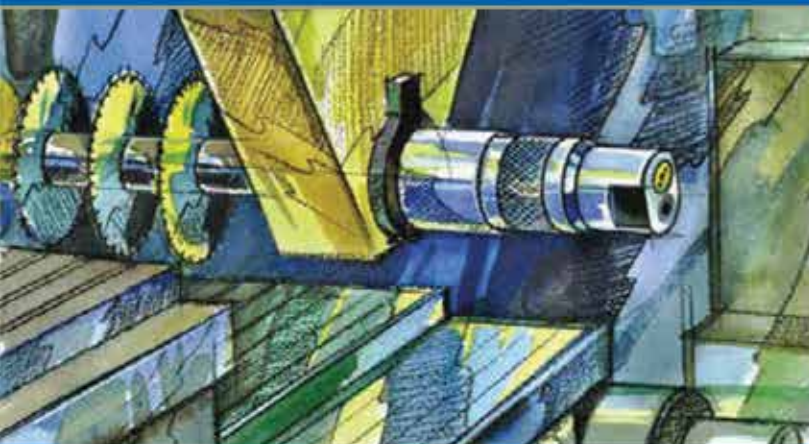

Obtained by installing a clamping pressure indicator in the hydraulic lock nut POLYMA.

Screw hydraulic lock nut by hand onto the end of the arbor in place of the mechanical nut. Series of tests at customers factories have shown, that in the case of gear hobbing machines depending on the required degree of precision there is no need to align the hob cutter. The gear hob can be aligned quickly and easily as the need arises, since the hydraulic lock nut is only hand-tightened.



The self-contained hydraulic system is actuated by tightening the pressure screw on the end face using the supplied wrench. The magnitude of the effective axial force is adjusted and monitored by the 2-stage clamping pressure indicator. The parts to be clamped are pressed together by the purely axial thrust on the hydraulic piston.

Since no radial or transverse forces are generated during the clamping process, the set degree of concentricity is maintained throughout the edge life of the milling cutter.

This ensures an improved machining result and shorter machining times during subsequent operations, as well as prolongation of the edge life. Depending on the application, it is possible to dispense with the key coupling and so avoid damage to the cutter arbor. The cutter is easy to change and there is no need for the customary extended wrenches or hammers, thus helping to reduce setup time and prevent accidents.

Conversion parts are available for adapting the hydraulic lock nut to the arbor thread and diameter.

Hydraulic lock nut D89

With clamping pressure indicator

UNI-TECH ENGINEERS

Corporate Office :

Plot No. 106/2, T-Block, Shop No. 36,
 Rajgurunagar Industrial Complex,
 Bhosari, Pune, Maharashtra - 411 026

sales@uni-techengineers.com | unitechengineers12@gmail.com

POLYMA-PRIMA

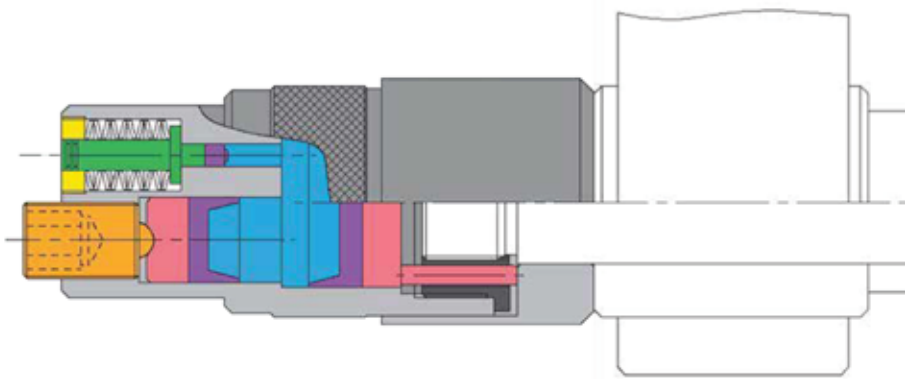

Technical Data

Please specify arbor O.D. and thread when ordering.

Order No.	Arbor diameter to		Max. clamping force kN	Marked ring	Pressure indicator Clamping force	
	mm	inch			kN	lbs
D89-100	32	1.25	120	1	60	13200
				2	120	26400
D89-200	50	2.0	150	1	60	13200
				2	100	22000
				3	150	33000

Dimensions

Order No.	Dimensions (mm)					
	Ø D	Ø d ₁	Ø d ₂	L	L ₁	L ₂ *
D89-100	to 32	50	65	140	100	7
D89-200	to 50	50	83	155	115	7

*L₂ = untied screw

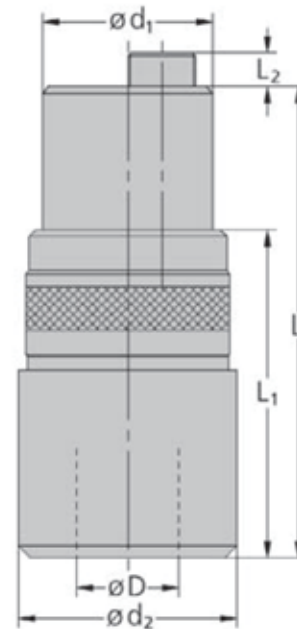

Subject to technical alterations

Hydraulic lock nut D91-A

With clamping pressure indicator

POLYMA-PARVA

POLYMA PARVA

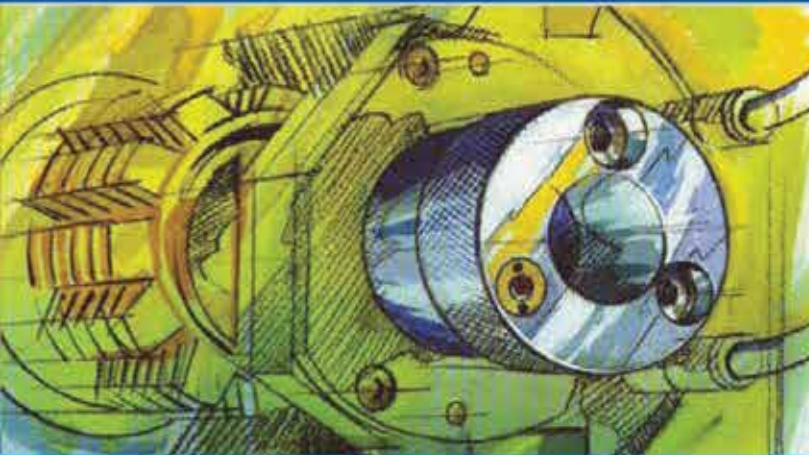

This dimension series was prompted by the widespread demand for countersunk pressure screws.

The strong, purely axial, defined and monitored clamping pressure (by comparison with the mechanical clamping nut) is ensured by the self-contained hydraulic system.

Tighten the hydraulic lock nut by hand and actuate the self-contained hydraulic system by tightening the two pressure screws on the end face with an Allen wrench. The hydraulic pressure causes



the parts to press together by a purely axial power.

The hydraulically cushioned clamping surface adapts to the opposite surface and clamps the part with a secure, defined axial power. The magnitude of the effective axial power is adjusted and monitored by the multi-stage clamping pressure indicator. If necessary, the calibration of the clamping pressure can be altered at the factory.

The transverse power which is inevitably generated with mechanical clamping, and which causes the parts to be displaced, does not occur with this lock nut, and preset concentricity is maintained throughout the edge life of the cutter. Thus, ensuring better machining results and shorter times for finishing operations.

Large wrench extensions and hammers are a thing of the past. A genuine contribution to reduced setup times, accident prevention and labour saving.

Hydraulic lock nut D91-A

With clamping pressure indicator

POLYMA-PARVA

UNI-TECH ENGINEERS

Corporate Office :

Plot No. 106/2, T-Block, Shop No. 36,
Rajgurunagar Industrial Complex,
Bhosari, Pune, Maharashtra - 411 026

sales@uni-techengineers.com | unitechengineers12@gmail.com

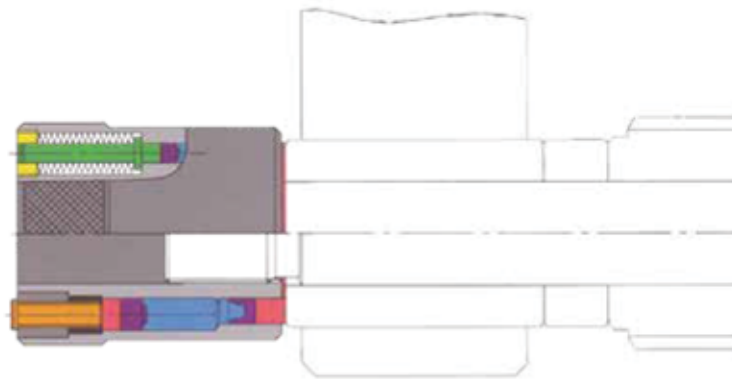

Technical Data

Please specify arbor O.D. or thread when ordering.

Order No.	Arbor diameter to		Max. clamping force kN	Marked ring	Pressure indicator Clamping force	
	mm	inch			kN	lbs
D91-A24	24	0.937	40	1	20	4400
				2	40	8800
D91-A32	32	1.25	60	1	30	6600
				2	60	13200
D91-A40	40	1.5	150	1	60	13200
				2	100	22000
				3	150	33000
091-A50	50	2.0	150	1	60	13200
				2	100	22000
				3	150	33000
091-A60	60	2.375	200	1	60	13200
				2	100	22000
				3	200	44000
091-A80	80	3.125	250	1	60	13200
				2	150	33000
				3	250	55000

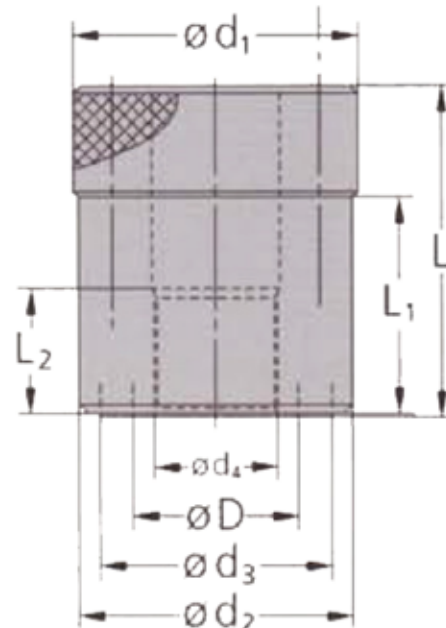

Dimensions

Order No.	Dimensions (mm)							
	$\varnothing D$	$\varnothing d_1$	$\varnothing d_2$	$\varnothing d_3$	$\varnothing d_4$	L	L_1	L_2
091-A24	to 24	47	46	34	to 20	69	42	25
D91-A32	to 32	57	56	45	to 24	69	42	25
091-A40	to 40	69	67	56	to 30	95	55	35
D91-A50	to 50	83	80	68	to 42	95	55	35
D91-A60	to 60	98	95	80	to 52	86	50	35
091-A80	to 80	118	115	100	to 68	86	50	35

Hydraulic lock nut D91-A

With clamping pressure indicator

POLYMA-PARVA

POLYMA PARVA



With this lock nut it is possible to achieve a strong, purely axial clamping force capable of being defined and monitored, even with the shortest lengths and end-on force induction. Any axial run-out is compensated for by the hydraulically cushioned clamping surface.

These are the main advantages by comparison with mechanical clamping. Tighten the lock nut by hand and actuate the self-contained hydraulic system by tightening the pressure screw on the end face. The pressure intensifier generates



A force many times stronger than that obtainable by mechanical means.

The clamping power is steplessly adjustable, but can be reduced on request and does not generate any transverse forces to displace the clamped parts.

The set degree of concentricity is maintained throughout the machining process. The customary extended wrenches or hammers are no longer required a significant contribution to easier operations, reduced setup times and accident prevention.



Hydraulic lock nut D91-A

With clamping pressure indicator

POLYMA-PARVA

UNI-TECH ENGINEERS

Corporate Office :

Plot No. 106/2, T-Block, Shop No. 36,
Rajgurunagar Industrial Complex,
Bhosari, Pune, Maharashtra - 411 026

sales@uni-techengineers.com | unitechengineers12@gmail.com

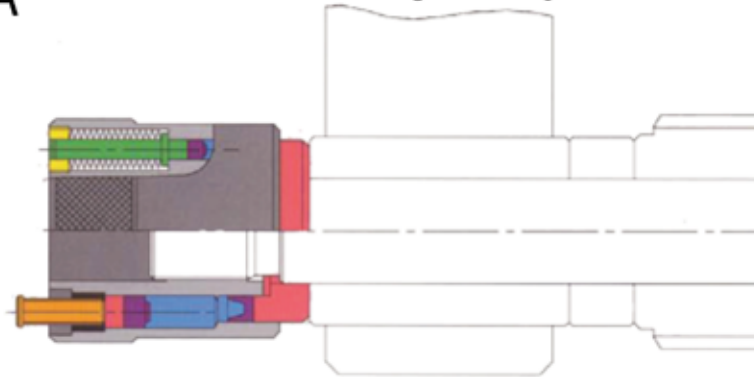

Technical Data

Please specify arbor O.D. or thread when ordering.

Order No.	Arbor diameter to		Max. clamping force kN	Marked ring	Pressure indicator Clamping force	
	mm	inch			kN	lbs
091-100	32	1.5	150	1	60	13200
				2	100	22000
				3	150	33000
091-200	50	2.25	150	1	60	13200
				2	100	22000
				3	150	33000
091-300	70	2.75	200	1	60	13200
				2	100	22000
				3	200	44000
091-400	85	3.25	250	1	80	17600
				2	150	33000
				3	250	55000
091-500	100	4.125	250	1	80	17600
				2	150	33000
				3	250	55000
091-600	120	4.75	300	1	80	17600
				2	150	33000
				3	300	66000

Dimensions

Order No.	Dimensions (mm)								
	Ø D	Ø d ₁	Ø d ₂	Ø d ₃	Ø d ₄	L	L ₁	L ₂	L ₃
091-100	to 32	69	66	56	to 30	80	44	35	8
D91-200	to 50	89	86	74	to 45	80	44	35	8
091-300	to 70	109	106	85	to 60	80	44	40	4
D91-400	to 85	122	120	100	to 75	80	44	40	4
D91-500	to 100	133	130	120	to 85	95	47	45	4
091-600	to 120	150	147	132	to 100	95	47	45	0

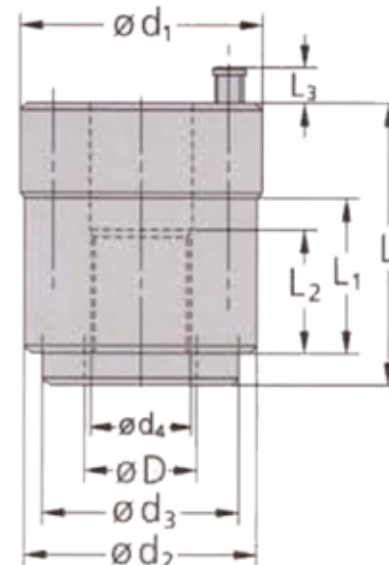

Subject to technical alterations

L3 - untied screw

Hydraulic clamping device D92

With clamping pressure indicator

POLYMA-MINORA

POLYMA MINORA

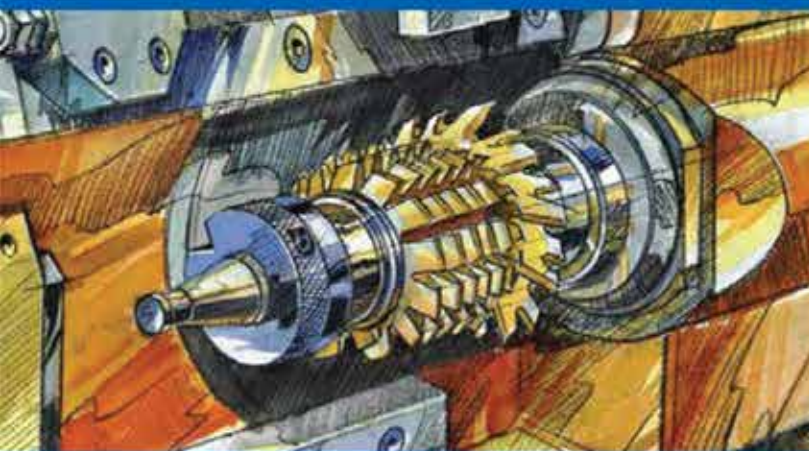

Extremely versatile hydraulic clamping device. It can be used as a nut, screw or spacer ring. For special applications, the annular clamping surface can be inwardly or outwardly adapted.

The pressure screws, positioned secantally in the base frame, allow an extremely low design. The self-contained hydraulic system is actuated by the pressure screws. The axial clamping power thus generates amounts to many times being obtainable by mechanical means, regardless of the mechanical prestressing.



The effective clamping pressure is adjusted and monitored by what is usually a 2-stage secantal clamping pressure indicator, according to the internal hydraulic pressure.

The hydraulic pressure does not generate any radial force, so that the parts remain in the aligned position. The hydraulically cushioned clamping surface allows a secure, defined axial clamping pressure, even in the case of non-parallel parts. The aids required for mechanical clamping, such as wrench, extensions and hammers are not required in the case, which means a further contribution to labour saving, accident prevention and reduced setup times.



POLYMA-MINORA

UNI-TECH ENGINEERS

Corporate Office :

Plot No. 106/2, T-Block, Shop No. 36,
Rajgurunagar Industrial Complex,
Bhosari, Pune, Maharashtra - 411 026

sales@uni-techengineers.com | unitechengineers12@gmail.com

Technical Data

Please specify arbor O.D. or thread when ordering.

Order No.	Arbor diameter to		Max. clamping force kN	Marked ring	Pressure indicator Clamping force	
	mm	inch			kN	lbs
D92-080	18	0.625	40	1	40	8800
D92-084	24	0.75	50	1	50	11000
D92-091	27	1.0	50	1	50	11000
D92-100	32	1.25	60	1/2	30/60	6600/13200
D92-200	40	1.5	70	1/2	30/70	6600/15400
D92-300	50	2.0	80	1/2	40/80	8800/17600
D92-400	60	2.375	100	1/2	60/100	13200/22000
D92-500	70	2.75	120	1/2	60/120	13200/26400
D92-600	80	3.125	150	1/2	80/150	17600/33000
D92-700	100	3.875	200	1/2	100/200	22000/44000
D92-800	120	4.75	200	1/2	100/200	22000/44000
D92-900	140	5.5	250	1/2	120/250	26400/55000
D92-1000	160	6.25	250	1/2	120/250	26400/55000

Dimensions

Order No.	Dimensions (mm)				
	Ø D	Ø d ₁	Ø d ₂	Ø d ₃	L
D92-080	to 18	34	24	57	30
D92-084	to 24	52	42	60	33
D92-091	to 27	52	42	65	33
D92-100	to 32	56	40	70	33
D92-200	to 40	62	50	75	33
D92-300	to 50	74	60	85	33
D92-400	to 60	85	70	100	33
D92-500	to 70	100	85	119	33
D92-600	to 80	120	105	130	33
D92-700	to 100	132	120	150	47
D92-800	to 120	160	138	173	47
D92-900	to 140	175	155	198	47
D92-1000	to 160	200	180	220	47

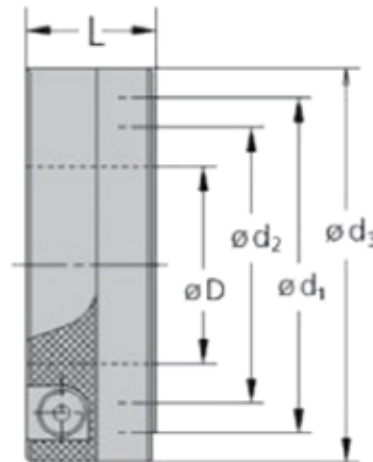
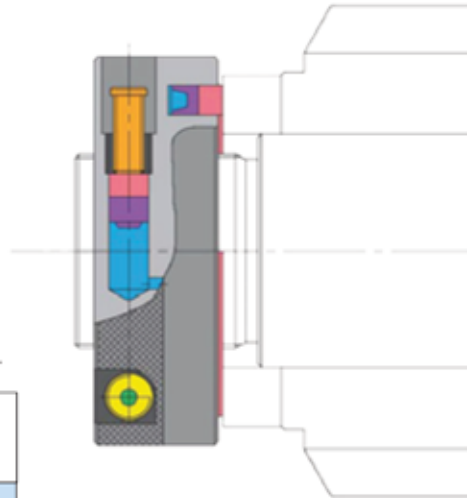

Hydraulic lock nut D93-0

With clamping pressure indicator

POLYMA-BREVA

POLYMA BREVA



Compared to the previous series reducible weight makes it even more versatile.

Operation is extremely simple. Screw on the hydraulic lock nut by hand as you would a mechanical nut. The self-contained hydraulic system is actuated by the pressure screw on the end face for two pressure screws in the case of diameters from 42 mm or (1.625 inch upwards).

The axial clamping pressure generates amounts to many times being obtainable by mechanical means, regardless of the mechanical pre-stressing.



The effective clamping pressure is adjusted and monitored by the one-stage clamping pressure indicator on the end face according to the built-up internal hydraulic pressure.

The clamping process does not generate any transverse powers to displace the parts from their preset, aligned position. The hydraulically cushioned clamping surface ensures a secure, defined axial clamping pressure enabling any minor axial run-out to be compensated for.

By setting bores on the end face (measures $0 d_x$ x LJ) the mass can be reduced and/or the hydraulic lock nut be balanced.

Out or inwardly adapted annular clamping surfaces are also available for special applications, while large, extended wrenches can simply be eliminated.

Hydraulic lock nut D93-0

With clamping pressure indicator

UNI-TECH ENGINEERS

Corporate Office :

Plot No. 106/2, T-Block, Shop No. 36,
Rajgurunagar Industrial Complex,
Bhosari, Pune, Maharashtra - 411 026

sales@uni-techengineers.com | unitechengineers12@gmail.com

POLYMA-BREVA

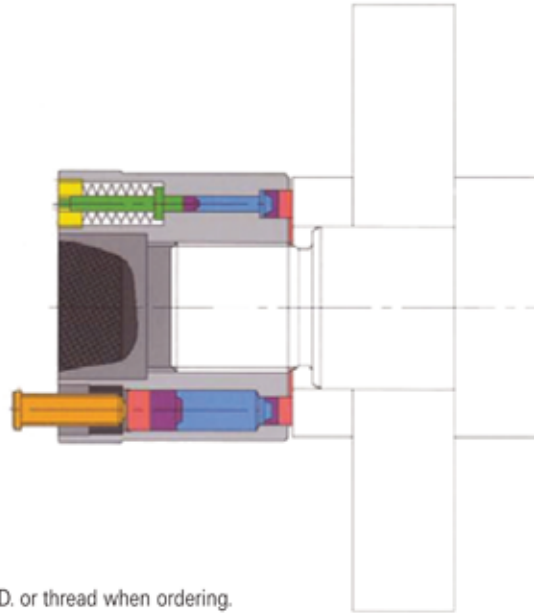

Technical Data

Please specify arbor O.D. or thread when ordering.

Order No.	Arbor diameter to		Max. clamping force kN	Marked ring	Pressure indicator Clamping force	
	mm	inch			kN	lbs
093-0016	16	0.625	30	1	30	6600
093-0020	20	0.75	40	1	40	8800
093-0024	24	0.875	50	1	50	11000
093-0130	30	1.125	60	1	60	13200
093-0136	36	1.375	70	1	70	15400
093-0142	42	1.625	80	1	80	17600
093-0152	52	2.0	100	1	100	22000
093-0168	68	2.625	120	1	120	26400

Dimensions

Order No.	Dimensions (mm)								
	$\varnothing D$	$\varnothing d_1$	$\varnothing d_2$	$\varnothing d_3$	L	L_1	L_2	d_4	L_4
093-0016	to 16	45	24	36	47	24	4	11	32
093-0020	to 20	49	28	40	50	26	5	11	35
093-0024	to 24	55	32	46	52	28	7	11	37
093-0130	to 30	61	38	52	66	30	7	11	41
093-0136	to 36	67	44	58	68	32	11	11	43
093-0142	to 42	81	54	70	62	32	6	12.5	37
093-0152	to 52	91	64	80	65	32	7	12.5	40
093-0168	to 68	107	78	94	66	35	10	12.5	41

*L2 - untied screw

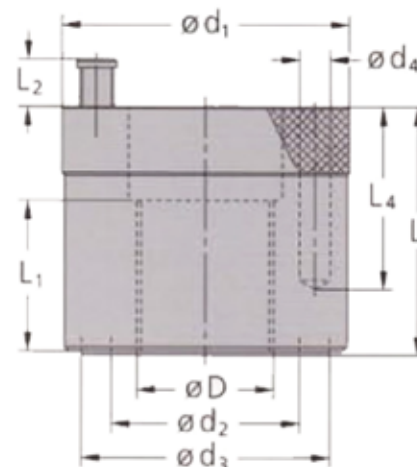

Subject to technical alterations

Hydraulic lock nut D93-N28/D93-N30

With clamping pressure indicator

POLYMA-BREVA

POLYMA BREVA



To clamp the grinding wheel on tooth flank grinding machines.

The mechanical nut is simply replaced by the hydraulic lock nut. The hydraulic lock nut serves to clamp the grinding wheel, independently how tightly the nut is screwed on by hand, with a defined, purely axial force, which is set and monitored by the clamping pressure indicator.

The force is built up by the self-contained hydraulic system by tightening the screws, so that there is no need for wrench



extensions or spindle steady devices, and no risk of radial movements. For tightening and loosening the clamping nut in enclosed applications, a special wrench is available (No. D93-N28.20), which is engaged in the bores on the end face.

D93-N28 for REISHAUER Machines. D93-N30 for GLEASON/OKAMOTO Machines.

Hydraulic lock nut D93-N28/D93-N30

With clamping pressure indicator

POLYMA-BREVA

UNI-TECH ENGINEERS

Corporate Office :

Plot No. 106/2, T-Block, Shop No. 36,
Rajgurunagar Industrial Complex,
Bhosari, Pune, Maharashtra - 411 026

sales@uni-techengineers.com | unitechengineers12@gmail.com

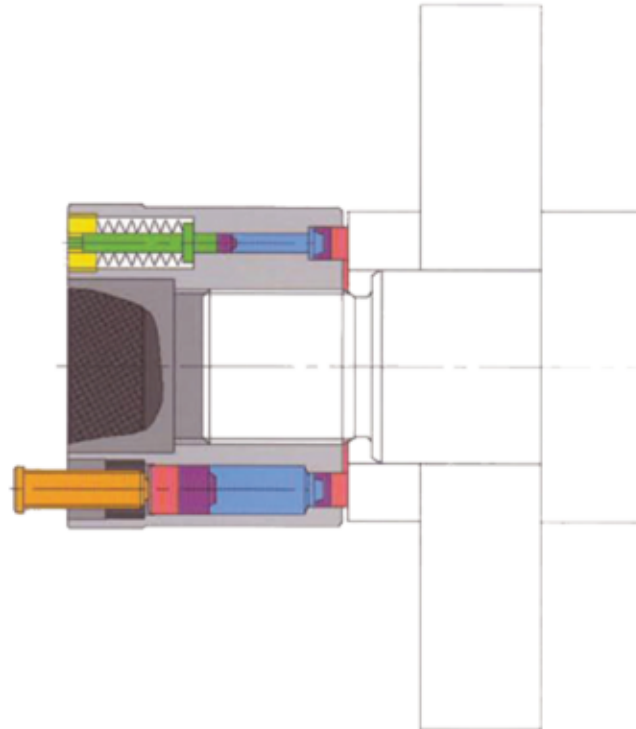

Technical Data

Order No.	Arbor diameter to mm	Max. clamping force kN	Pressure indicator Clamping force		
			pin	kN	lbs
D93-N28	M28x1.5LH	30	plane	30	6600
D93-N30	M30x1.5LH	30	plane	30	6600

Dimensions

Order No.	Dimensions (mm)					
	Ø D	Ø d ₁	Ø d ₂	Ø d ₄	L	L ₂ *
D93-N28	28	70	50	62	38	6
D93-N30	30	56	35	45	54	-

*L₂ = untied screw

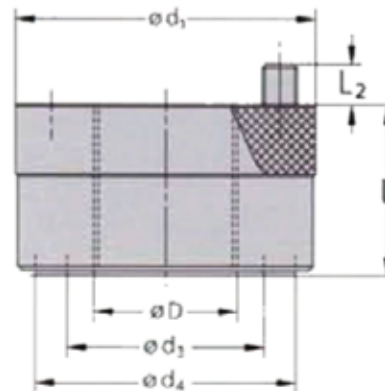

Subject to technical alterations

Hydraulic Lock Nut

D98 with clamping pressure indicator,
DAK98 with clamping pressure indicator,
equalizing wedges

POLYMA-PROCERA

POLYMA PROCERA



The request of the market for a lock nut with an outer diameter as small as possible with a good hydraulic pressure transmission, which is initiated by an Allen wrench and combined on request with the possibility to optimize the concentricity of the hob, resulted in this solution.

The hydraulic lock nut is screwed on to the arbor by hand. With an Allen wrench SW4 the desired clamping pressure is built up, depending on the arbor diameter. The value of the effective, purely axial clamping pressure is adjusted and monitored by the



clamping pressure indicator/ control. To build up the clamping pressure a torque less 5 Nm is required at the pressure screws.

The hydraulic lock nut is also offered with an integrated alignment ring, especially for hob clamping.

By the equalizing wedges incorporated in the alignment ring the concentricity of the hob can be, beginning at the lowest point, specifically influenced and thereby optimized.

When choosing the hydraulic lock nut or the alignment ring, please notice:

The arbor- \emptyset and hob spacer ring outside- \emptyset should correspond to dimensions d1 and d2.

If this is not possible, the following thumb rule should be applied, when choosing the appropriate alignment ring: Cutter-/spacer ring outside- \emptyset = d1 \pm 5 mm.

Dimensions of alignment rings only see: Alignment Ring FACERA No. AK76.

POLYMA-PROCERA

UNI-TECH ENGINEERS

Corporate Office :
Plot No. 106/2, T-Block, Shop No. 36,
Rajgurunagar Industrial Complex,
Bhosari, Pune, Maharashtra - 411 026

sales@uni-techengineers.com | unitechengineers12@gmail.com

Technical Data

Please specify arbor O.D. or thread when ordering.

Order No.	Arbor diameter to		Max. clamping force kN	Pressure indicator		
	mm	inch		Marked ring	Clamping force	
				kN	lbs	
098-116	16	0.625	40	plane	40	8800
098-122	22	0.866	50	plane	50	11000
098-132	32	1.25	60	plane	60	13200

Technical Data Data DAK98

Order No.	Arbor diameter to		Max. clamping force kN	Pressure indicator		
	mm	inch		Marked ring	Clamping force	
				kN	lbs	
OAK98-013	M12x1,0	0.625	20	plane	20	4400
DAK98-016	M16x1,5	0.866	40	plane	40	8800
OAK98-022	M22x1.5	1.0	50	plane	50	11000
OAK98-027	M25x1,5	1.25	60	plane	60	13200
DAK98-032	M25x1.5	1.5	60	plane	60	13200

OAK98-116	16	0.625	40	plane	40	8800
DAK98-122	22	0.866	50	plane	50	11000
DAK98-132	32	1.25	60	plane	60	13200

Dimensions

Order No.	Dimensions (mm)						
	Ø D MAX	Ø d ₁	Ø d ₂	L	L ₁	L ₂	L ₃
098-116	16	36	16	-	40	29	12
098-122	20	42	20	-	40	29	12
098-132	30	52	32	-	54	43	19

Order No.	Dimensions (mm)						
	Ø D MAX	Ø d ₁	Ø d ₂	L	L ₁	L ₂	L ₃
OAK98-013	M12x1,0	36	13	56	40	29	12
OAK98-016	M16x1.5	36	16	56	40	29	12
OAK98-022	M20x1,5	42	20	56	40	29	12
OAK98-027	M25x1,5	52	27	70	54	43	19
DAK98-032	M25x1,5	52	32	70	54	43	19

DAK98-116	16	36	16	56	40	29	12
OAK98-122	20	42	20	56	40	29	12
DAK98-132	30	52	32	70	54	43	19

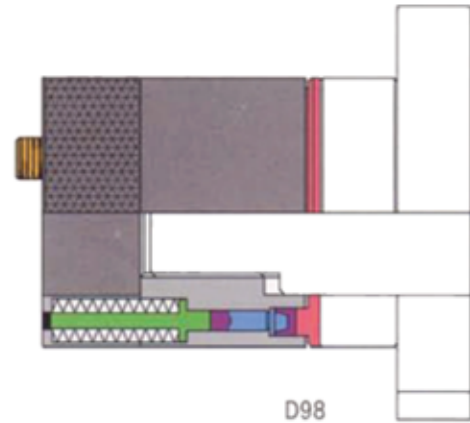

D98

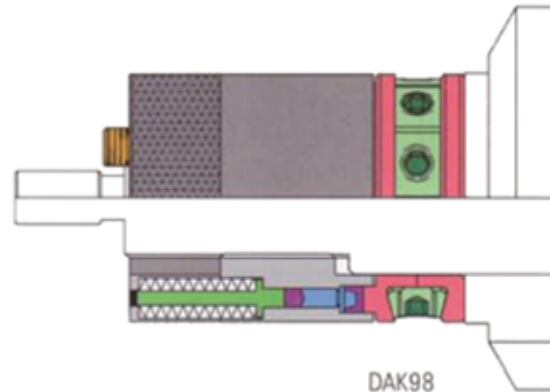

DAK98

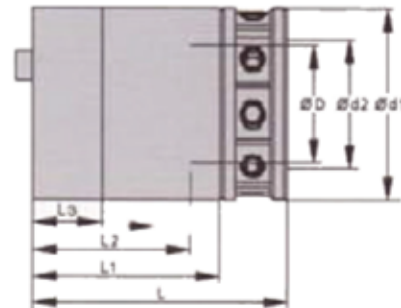

Subject to technical alterations

Hydraulic lock nut DA92

With clamping pressure indicator, equalizing screws

POLYMA-ACCURATA

POLYMA ACCURATA



Concentricity is a very important consideration for hob clamping. To improve the accuracy of the concentricity, equalizing screws and a corresponding annular piston have been added to the well-tried hydraulic lock nut POLYMAMINORA No. D92.

As usual, the hydraulic lock nut is screwed onto the arbor. A purely axial clamping force is built up by means of the two pressure screws, being arranged radially on the circumference,



via the self-contained hydraulic system. The clamping pressure indicator is used to set up and monitor the effective clamping pressure.

The hob pre-tensioned in this way may be optimised in its concentricity at the side of the hydraulic lock nut when mounted to the machine.

The arrangement of the alignment screws on the circumference at an angle of approx. 15° which affect the annular piston, makes it possible to optimise the concentricity with a fully axial force load and mounted thrust bearing.



UNI-TECH ENGINEERS

Corporate Office :

Plot No. 106/2, T-Block, Shop No. 36,
Rajgurunagar Industrial Complex,
Bhosari, Pune, Maharashtra - 411 026

sales@uni-techengineers.com | unitechengineers12@gmail.com

POLYMA-ACCURATA

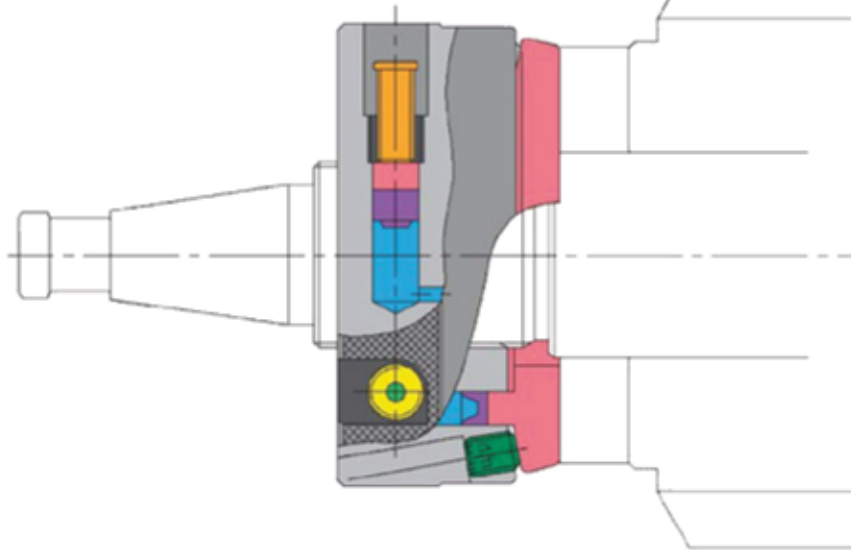

Technical Data

Please specify arbor O.D. and thread when ordering.

Order No.	Arbor diameter to		Max. clamping force kN	Marked ring	Pressure indicator Clamping force	
	mm	inch			kN	lbs
DA92-G012	12	0.5	25	1	25	5500
DA92-G016	16	0.625	40	1	40	8800
DA92-G020	22	0.875	50	1	50	11000
DA92-G030	32	1.25	60	1	60	13200
DA92-G036	40	1.5	100	1	100	22000

Dimensions

Order No.	Dimensions (mm)				
	Ø D	Ø d ₁	Ø d ₂	Ø d ₃	L
DA92-G012	to 12	36	16	50	35
DA92-G016	to 16	36	16	55	35
DA92-G020	to 20	56	22	63	35
DA92-G030	to 30	64	32	71	35
DA92-G036	to 36	72	40	79	45

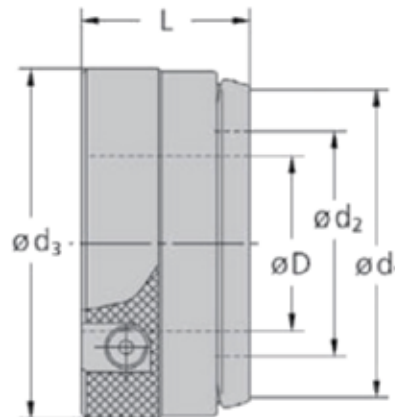

Hydraulic mechanical lock nut DAKK105

With clamping pressure indicator,
equalizing wedges, hydraulic retract

POLYMA-ADJUSTA

POLYMA ADJUSTA

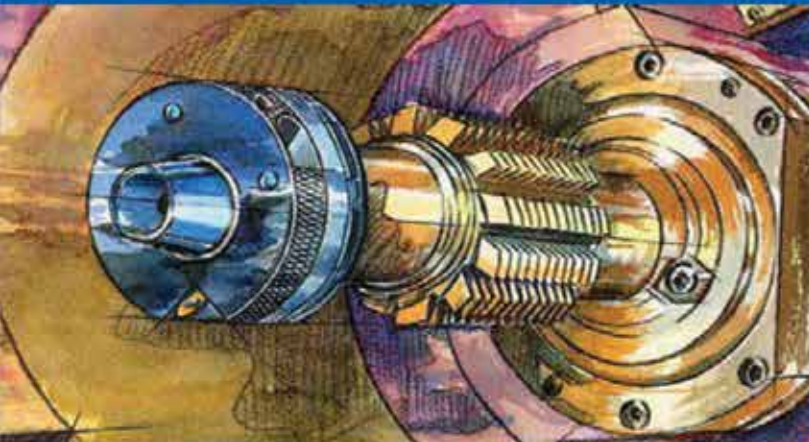

Hydraulic clamping devices produce a strong, purely axial clamping pressure, capable of being defined and monitored, also having a floating clamping surface.

As already known from the hydraulic lock nut POLYMA-ADJUSTA DAKK92, the insertion of a flange between the arbor and the lock nut prevents the part to be clamped from being displaced, even by a micrometer, in the radial direction.

Especially for the LIEBHERR-hobbing machines this lock nut was designed for arbor diameters



<25 mm (1") because the cone, which is necessary to adapt the counter stay, is already integrated in the inserted flange. Based on the also integrated bevel spring the flange in addition takes over the reset of the hydraulic system into the zero starting point position, when released.

Built-in wedge segments in the annular piston allow optimal concentricity by increasing the buckling strength in conjunction with the flange and clamping device.

Operation:

- Mount shaft as vertically as possible.
- Generate desired axial clamping power according to clamping power indicator.
- Check concentricity.
- Align via wedges. Begin by correcting at the lowest point of rotation. Continue correcting by actuating the wedges until the gear hob reaches the desired degree of concentricity. Wedges should not protrude past the outer diameter of the hydraulic clamping device.
- Tighten all unused wedges by hand so they just make contact.



Hydraulic mechanical lock nut DAKK105

With clamping pressure indicator,
equalizing wedges, hydraulic retract

UNI-TECH ENGINEERS

Corporate Office :

Plot No. 106/2, T-Block, Shop No. 36,
Rajgurunagar Industrial Complex,
Bhosari, Pune, Maharashtra - 411 026

sales@uni-techengineers.com | unitechengineers12@gmail.com

POLYMA-ADJUSTA

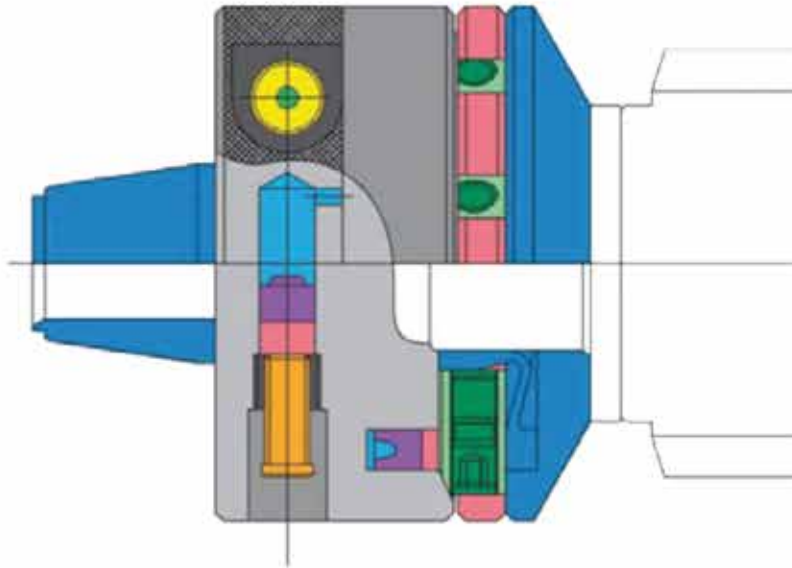

Technical Data

Order No.	Thread Ø mm	Max. clamping force kN	Marked ring	Pressure indicator	
				Clamping force kN	Clamping force lbs
DAKK105-008	M8x1,0LH	12	1	12	2640
DAKK105-010	M10x1,0LH	15	1	15	3300
DAKK105-013	M12x1,5LH	20	1	20	4400
DAKK105-016	M14x1,5LH	30	1	30	6600
DAKK105-019	M18x1,5LH	40	1	40	8800
DAKK105-022	M18x1,5LH	50	1	50	11000
DAKK105-025	M18x1,5LH	50	1	50	11000

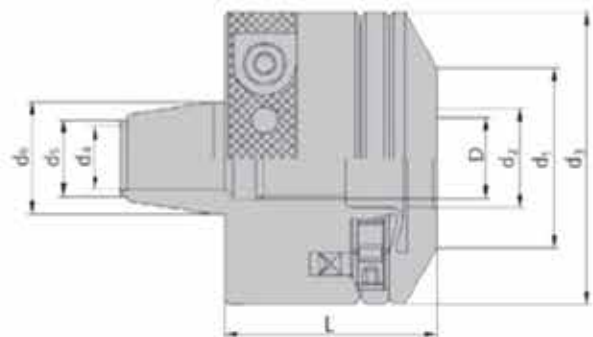

Dimensions

Order No.	Dimensions (mm)							
	Ø D	Ø d ₁	Ø d ₂	Ø d ₃	Ø d ₄	Ø d ₅	Ø d ₆	L
DAKK105-008	M8x1,0LH	30	8	65	6	17	25	50
DAKK105-010	M10x1,0LH	30	10	65	8	17	25	50
DAKK105-013	M12x1,5LH	30	13	65	10	17	25	50
DAKK105-016	M14x1,5LH	30	16	65	12	17	25	50
DAKK105-019	M18x1,5LH	40	19,1	65	14	17	25	50
DAKK105-022	M18x1,5LH	40	22	65	14	17	25	50
DAKK105-025	M18x1,5LH	40	25,4	65	14	17	25	47

Subject to technical alterations

Hydraulic mechanical lock nut DAKK92

With clamping pressure indicator,
equalizing wedges, hydraulic retract

POLYMA-ADJUSTA

POLYMA ADJUSTA

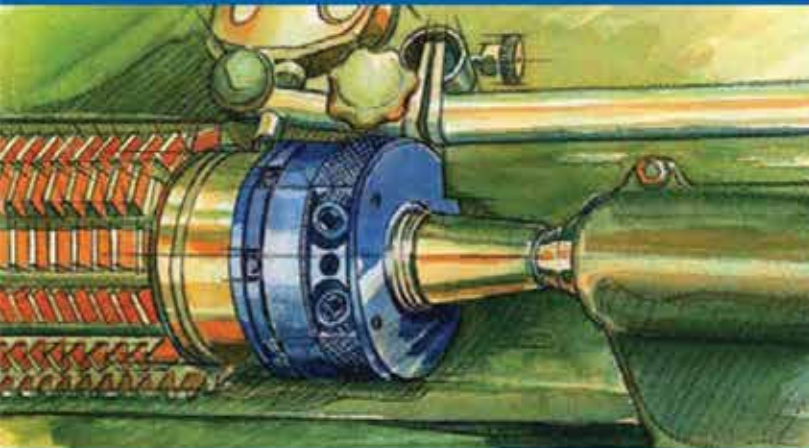

Hydraulic clamping devices produce a strong, purely axial clamping pressure, capable of being defined and monitored, also having a floating clamping surface.

The insertion of a flange between the arbor and lock nut prevents the part from being displaced, even by a micrometer, in the radial direction. The flange also has an integrated bevel spring which resets the hydraulic system to the zero/starting position when released. Built-in wedge segments in the annular piston allow optimal concentricity by increasing the buckling



strength in conjunction with the flange and clamping device.

Operation:

- Mount shaft as vertically as possible.
- Generate desired axial clamping power according to clamping power indicator.
- Check concentricity.
- Align via wedges. Begin by correcting at the lowest point of rotation. Continue correcting by actuating the wedges until the gear hob reaches the desired degree of concentricity. Wedges should not protrude past the outer diameter of the hydraulic clamping device.
- Tighten all unused wedges by hand so they just make contact.

Hydraulic mechanical lock nut DAKK92

With clamping pressure indicator, equalizing wedges, hydraulic retract

UNI-TECH ENGINEERS

Corporate Office :

Plot No. 106/2, T-Block, Shop No. 36,
Rajgurunagar Industrial Complex,
Bhosari, Pune, Maharashtra - 411 026

sales@uni-techengineers.com | unitechengineers12@gmail.com

POLYMA-ADJUSTA

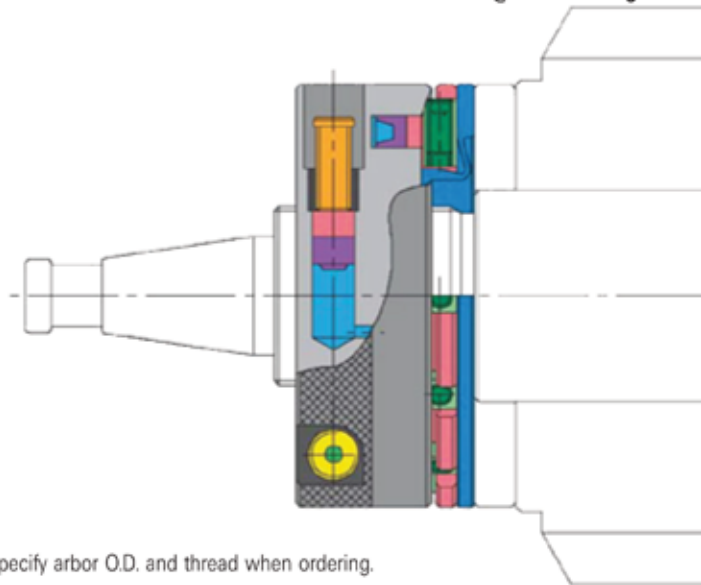

Technical Data

Please specify arbor O.D. and thread when ordering.

Order No.	Arbor diameter to		Max. clamping force kN	Marked ring	Pressure indicator Clamping force	
	mm	inch			kN	lbs
DAKK92-016	16	0.625	40	1	40	8800
DAKK92-022	22	0.866	50	1	50	11000
DAKK92-027	27	1.0	60	1/2	30/60	6600/13200
DAKK92-032	32	1.25	70	1/2	30/70	6600/15400
DAKK92-040	40	1.5	80	1/2	40/80	8800/17600
DAKK92-050	50	2.0	100	1/2	60/100	13200/22000
DAKK92-060	60	2.375	120	1/2	60/120	13200/26400
DAKK92-080	80	3.125	150	1/2	80/150	17600/33000
DAKK92-100	100	3.875	200	1/2	100/200	22000/44000

Dimensions

Order No.	Dimensions (mm)				
	Ø D	Ø d ₁	Ø d ₂	Ø d ₃	L
DAKK92-016	to 16	16	36	60	40
DAKK92-022	to 22	22	42	65	40
DAKK92-027	to 27	27	47	70	42
DAKK92-032	to 32	32	52	75	42
DAKK92-040	to 40	40	60	85	42
DAKK92-050	to 50	50	70	100	42
DAKK92-060	to 60	60	80	120	42
DAKK92-080	to 80	80	100	135	45
DAKK92-100	to 100	90	120	150	55

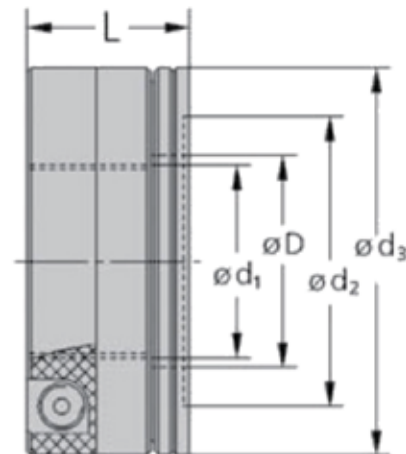

Subject to technical alterations

Hydraulic Lock nut DK92-E20

With clamping pressure indicator, hydraulic retract

POLYMA-MINORA

POLYMA MINORA

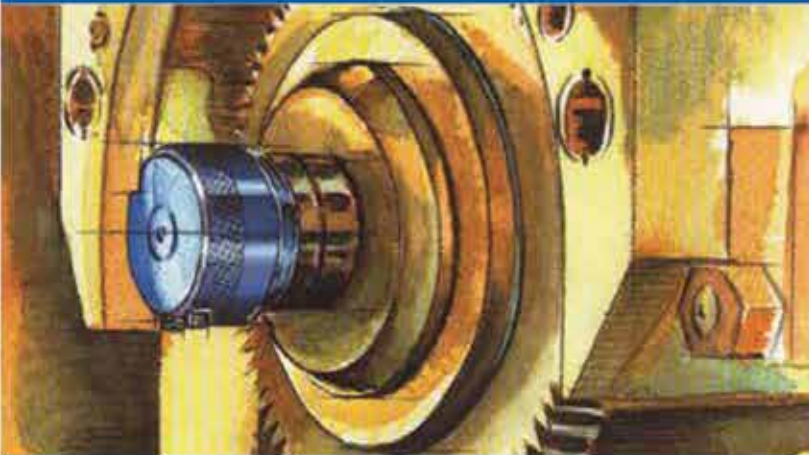

This specification was drawn up at the request of GLEASON-HURTH.

It can also be used for other purposes, however. The self-contained hydraulic system is actuated by tightening the screws and a purely axial pressure is generated by the clamping piston. At the same time the hydraulic resetting mechanism is activated by bevel springs mounted on the clamping piston.

The magnitude of the effective power can be monitored by the pressure indicator regardless of the mechanical pressure.



When the system is relieved by slackening the screws the hydraulic pressure collapses and the spring assembly resets the entire hydraulic system to its zero/starting position.

The wrench for tightening the mechanical nut is no longer necessary as well as arresting the spindle.



Hydraulic lock nut DK92-E20

With clamping pressure indicator, hydraulic retract

UNI-TECH ENGINEERS

Corporate Office :

Plot No. 106/2, T-Block, Shop No. 36,
Rajgurunagar Industrial Complex,
Bhosari, Pune, Maharashtra - 411 026

sales@uni-techengineers.com | unitechengineers12@gmail.com

POLYMA-MINORA

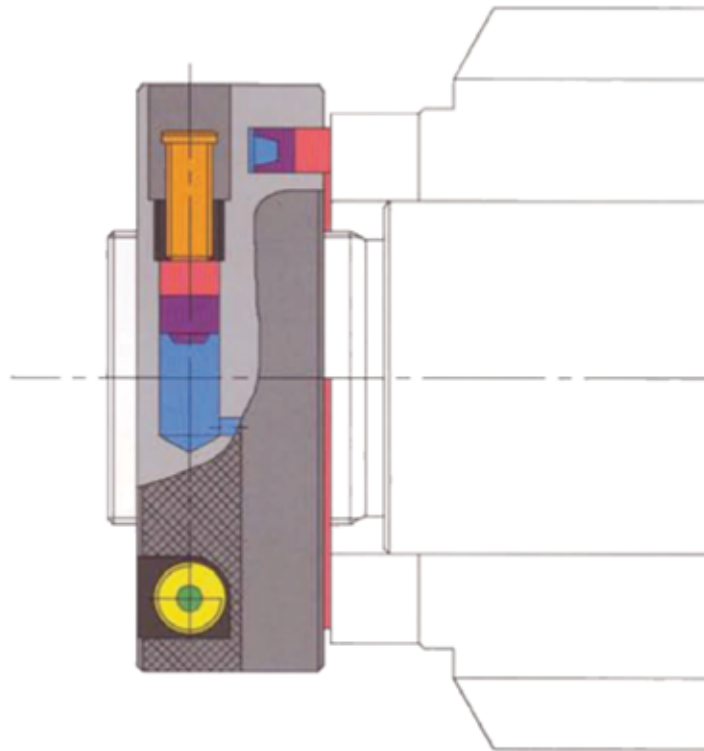

Technical Data

Please specify arbor O.D. and thread when ordering.

Order No.	Arbor diameter to		Max. clamping force kN	Marked ring	Pressure indicator Clamping force	
	mm	inch			kN	lbs
DK92-E20	22	0.875	40	1	40	8800

Dimensions

Order No.	Dimensions (mm)				
	$\varnothing d$	$\varnothing d_1$	$\varnothing d_2$	$\varnothing d_3$	L
DK92-E20	to 22	52	22	65	44

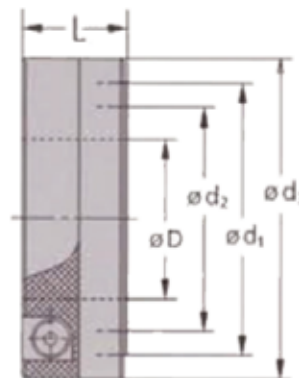

Subject to technical alterations

Hydraulic lock nut DK92-Z

With clamping pressure indicator, hydraulic retract

POLYMA-SICCA

POLYMA SICCA



As a result of the tendency to dry cutting, demands made on lock nuts are changing. Further development resulted from our experiences with the hydraulic lock nut POLYMA-MINORA D92.

The insertion of a flange has 2 functions :

- To prevent the radial movement of the hob even by micrometers.
- To reset the hydraulic to the zero / home position, when the internal pressure is reduced.



During dry hobbing, temperatures of 100°C may occur in the area of the lock nut. This requires the use of a special hydraulic medium and appropriate seals.

As usual, the lock nut is screwed onto the cutter arbor by hand. By screwing-in the pressure screws, the clamping force is increased corresponding to the data of the hydraulic lock nut and the requirements. Both pressure screws have to be tightened. The value of the effective pure axial clamping force can be read from the pressure indicator. By inserting the flange a concentricity of 10 µm is achievable, in most cases, without special alignment.

When the hob is changed, the keyed flange takes over the hydraulics retract function—after the pressure screws have been un-screwed – so that it is easier to unscrew the lock nut from the arbor.

Hydraulic lock nut DK92-Z

With clamping pressure indicator, hydraulic retract

UNI-TECH ENGINEERS

Corporate Office :

Plot No. 106/2, T-Block, Shop No. 36,
Rajgurunagar Industrial Complex,
Bhosari, Pune, Maharashtra - 411 026

sales@uni-techengineers.com | unitechengineers12@gmail.com

POLYMA-SICCA

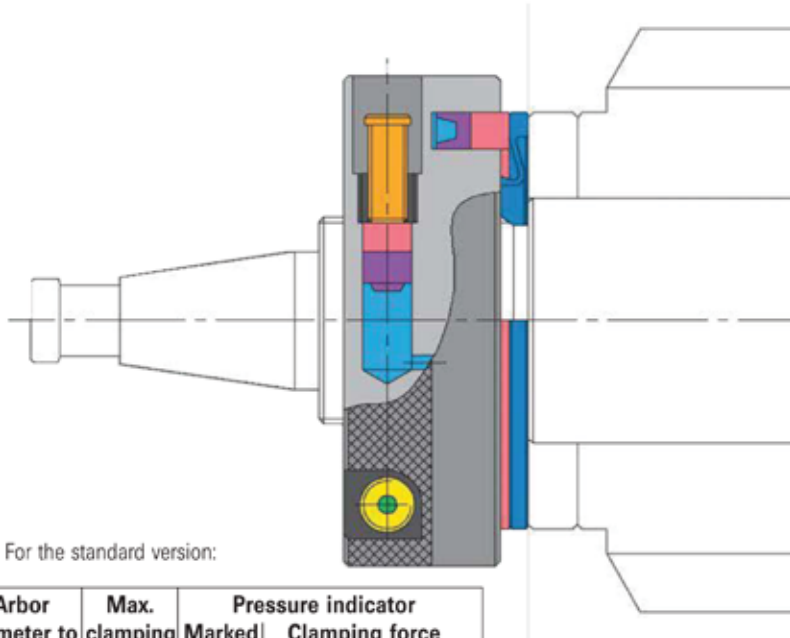

Technical Data

For the standard version:

Order No.	Thread mm	Arbor diameter to		Max. clamping force kN	Marked ring	Pressure indicator Clamping force	
		mm	inch			kN	lbs
DK92-Z027	M24x1,5LH	27	1.0	50	1	40	11000
DK92-Z032	M30x1,5LH	32	1.25	60	1/2	30/60	6600/13200
DK92-Z040	M36x2,0LH	40	1.5	70	1/2	30/70	6600/15400
DK92-Z050	M42x2,0LH	50	2.0	80	1/2	40/80	8800/17600
DK92-Z060	M52x2,0LH	60	2.375	100	1/2	60/100	13200/22000

For an additional charge, threads can be made according to your instructions. In this case, the order data is as follows:

DK92-Z127	to 24	27	1.0	50	1	40	11000
DK92-Z132	to 30	32	1.25	60	1/2	30/60	6600/13200
DK92-Z140	to 36	40	1.5	70	1/2	30/70	6600/15400
DK92-Z150	to 42	50	2.0	80	1/2	40/80	8800/17600
DK92-Z160	to 52	60	2.375	100	1/2	60/100	13200/22000

Dimensions

Order No.	Dimensions (mm)				
	Ø D	Ø d ₁	Ø d ₂	Ø d ₃	L
DK92-Z027 / DK92-Z127	to 24	52	44	65	36
DK92-Z032 / DK92-Z132	to 30	56	50	70	36
DK92-Z040 / DK92-Z140	to 36	62	56	76	36
DK92-Z050 / DK92-Z150	to 42	74	62	86	36
DK92-Z060 / DK92-Z160	to 52	85	72	100	36

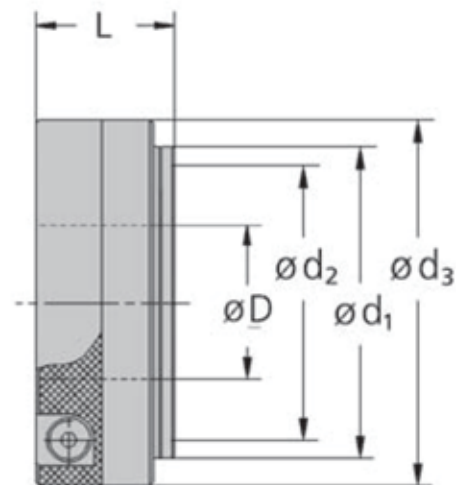

Hydraulic lock nut DK92

With clamping pressure indicator, hydraulic retract

POLYMA-MINORA

POLYMA MINORA



The versatility of the device led to the introduction of a hydraulic resetting mechanism, making it even easier and safer to operate, e.g. in applications without a spindle locking device.

Screw on the clamping device by hand and actuate the self-contained hydraulic system by tightening the secantal screws. The pressure built-up causes the clamping ring to move in the axial direction, while tension is applied to a spring acting on the clamping ring. If the hydraulic pressure is reduced by slackening the pressure screws.



The spring resets the entire hydraulic system to the zero or starting position. This means that there is no need to reset the hydraulic system manually via the nut thread, for example.

The hydraulic resetting mechanism limits the stroke of the annular piston to approx. 0,5 mm (0.02 inch), while retaining all the advantages and characteristics of the hydraulic clamping device, i.e. its ability to generate a purely axial - and, if need be - strong clamping power capable of being defined and monitored, using only an Allen wrench.

No transverse forces are generated to displace the parts from their correct position. The aids required for mechanical clamping, such as wrench extensions and hammers, can be eliminated. Thus, contributing to the goal of labour saving, accident prevention and reduced setup times.



Hydraulic lock nut 01(92)

With clamping pressure indicator, hydraulic retract

UNI-TECH ENGINEERS

Corporate Office :

Plot No. 106/2, T-Block, Shop No. 36,
Rajgurunagar Industrial Complex,
Bhosari, Pune, Maharashtra - 411 026

sales@uni-techengineers.com | unitechengineers12@gmail.com

POLYMA-MINORA

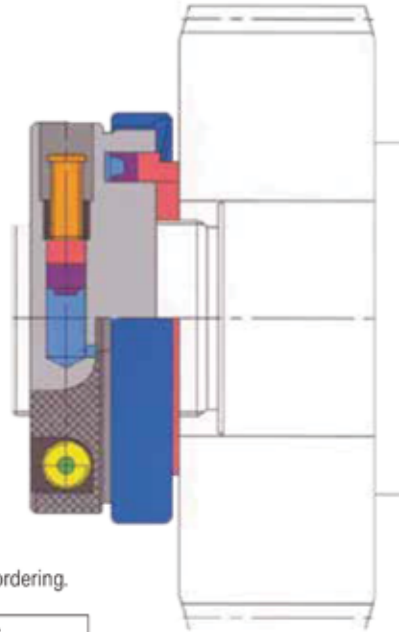

Technical Data

Please specify arbor O.D. and thread when ordering.

Order No.	Arbor diameter to		Max. clamping force kN	Pressure indicator		
	mm	inch		Marked ring	Clamping force	
					kN	lbs
OK92-400	60	2.375	100	1	60	13200
				2	100	22000
DK92-500	70	2.75	120	1	60	13200
				2	120	26400
DK92-600	80	3.125	150	1	80	17600
				2	150	33000
OK92-700	100	3.875	200	1	100	22000
				2	200	44000
DK92-800	120	4.75	200	1	100	22000
				2	200	44000
DK92-900	140	5.5	250	1	120	26400
				2	250	55000
OK92-1000	160	6.25	250	1	120	26400
				2	250	55000

Dimensions

Order No.	Dimensions (mm)								
	Ø D	Ø d1	Ø d2	Ø d3	Ø d4	L	L1	L2	L3
DK92-400	to 60	85	70	100	109	38	23	32	37
DK92-500	to 70	100	85	119	124	38	23	32	37
DK92-600	to 80	120	105	130	144	38	23	32	37
DK92-700	to 100	132	120	150	158	53	36	46	52
DK92-800	to 120	160	138	173	186	53	36	46	52
DK92-900	to 140	175	155	198	201	53	36	46	52
DK92-1000	to 160	200	180	210	226	53	36	46	52

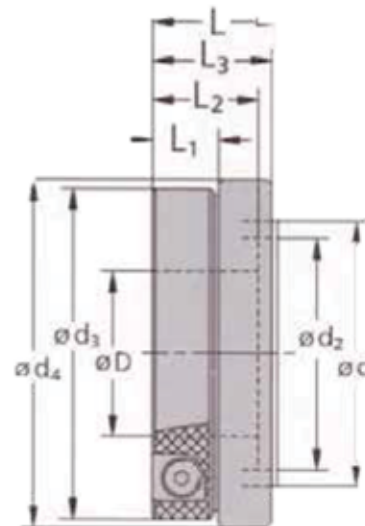

Hydraulic Lock Nuts

Granting of the patent in 1953 was the basis for the production of our hydraulic lock nuts.

Besides our standard program shown in our catalogue we manufacture a great variety of machine and customer-specific lock nuts.

Our hydraulic lock nuts are mainly used with machine tools, wood working machines and the food industry. Therefore our hydraulic lock nuts are manufactured from steel, stainless steel, and aluminium with the application-specific respective sealing and hydraulic medium.

It is self-evident that we manufacture besides our pressure-screw activated hydraulic lock nuts also lock nuts, where the hydraulic is activated via grease nipple/grease gun, hydraulic aggregate or machine hydraulic with pressure pin. Even the extent of the stroke at the ring piston can be adapted according to the requirements.

The "clamping" principle

How do hydraulic clamping elements work?

The actuation of the pressure screws or the addition of the hydraulic medium activates the self-contained hydraulic system with the pressure transformation.

This induces at the mostly annular hydraulic piston a force clamping the parts to be clamped on an arbour in a purely axial direction against a positive stop. The amount of the acting clamping pressure can be identified and monitored via an integrated pressure indicator.

Advantages:

- purely axial clamping pressure
- defined clamping pressure
- if needed, much higher clamping pressure
- floating clamping surface
- the part remains in the predefined position
- during the clamping procedure no radial forces

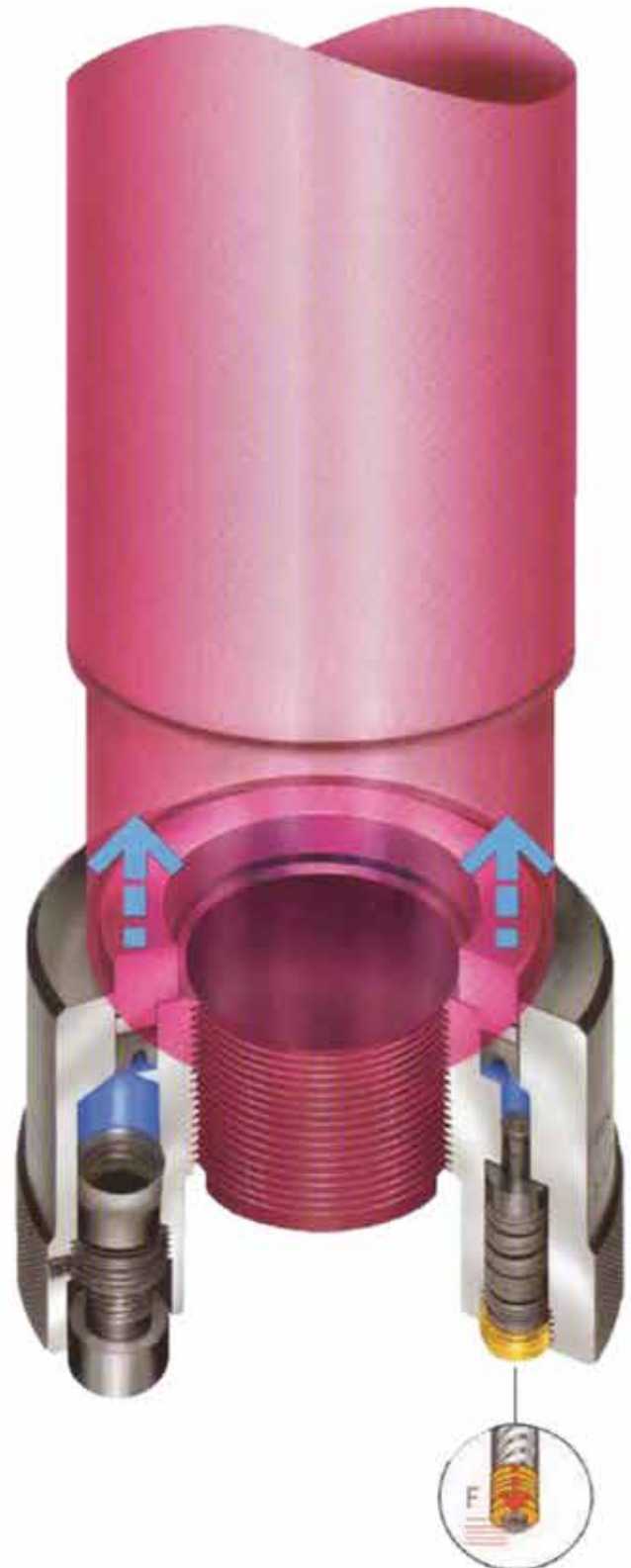

Hydraulic retract

Our hydraulic lock nuts are also available with hydraulic retract.

Constructions with hydraulic retract reset the hydraulic automatically to the zero/starting position as soon as the internal hydraulic pressure breaks down.



Possible combinations

Following some typical design examples are shown. Furthermore many additional designs and design combinations are conceivable.

Should you look for a solution of this type of task, simply ask us and we will readily help you.

- The clamping pressure can be achieved by
- Pressure screws :
For un-clamping turn back the pressure screws
- High pressure grease pump :
Un-clamping is achieved by release of the hydraulic medium with the drain plug
- Un-clamping is achieved by feeding back of the medium to the grease pump
- Fixed hydraulic connection
Un-clamping is achieved by feeding back of the medium into the hydraulic unit

Q-TECH PRECISION CLAMPINGS

Head Office: House No.5/8/77,
 Behind Govt. Press, Jahagirdar Colony,
 Railway Station, Aurangabad-431005.
sales@qtechclampings.com | www.qtechclampings.com

Examples



Nut



Pressure screw



Screw



High pressure grease pump



Clamping bush



Fixed hydraulic connection



Bayonet nut

Valuable Customers

 BAJAJ	 VE COMMERCIAL VEHICLES <small>A VEEDER GROUP AND Eicher MOTORS JOINT VENTURE</small>	 KALYANI	 MUSASHI
 HIM TEKNOFORGE LTD.	 CARRARO	 MICRO TURNERS	 BHARAT GEARS LIMITED <small>Careless for a life</small>
 IGW	 varroc	 RSB	 Jagdamba Auto-component Ltd
 Kirloskar	 SANJEEV <small>For Power Solutions</small>	 FLASH <small>FLASH ELECTRONICS (INDIA) PVT. LTD.</small>	 BHAVANI



QUALITY GRIPPING SOLUTIONS...



- Corporate Office :**
Plot No. 106/2, T-Block, Shop No. 36,
Rajgurunagar Industrial Complex,
Bhosari, Pune, Maharashtra - 411 026
- +91 7722 003 931 | +91 9923 355 227
- sales@uni-techengineers.com
unitechengineers12@gmail.com
- www.Uni-Techengineers.com